











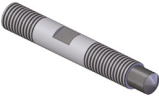

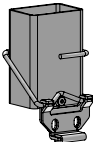

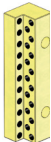

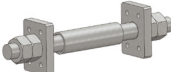

Die Components Normalien Componenti

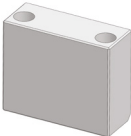

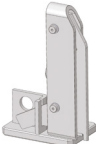
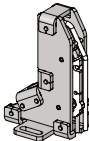











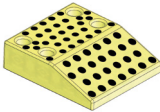

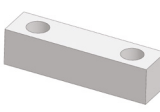

OMCR[®]
STANDARD DIE COMPONENTS

39D 506	39D 528	39D 543	39D 571	39D 578
				
<p>Sleeve Führungseinheit Canotto Guida</p>	<p>Gage Einweiser Riferimento</p>	<p>Brace Verlängerung Bretella</p>	<p>Tie Rod Führungsbolzen Tirante</p>	<p>Spacing bar Abstellbolzen Distanziale</p>
<p>546</p>	<p>546</p>	<p>547</p>	<p>547</p>	<p>548</p>
39D 578	39D 578	39D 582	39D 592	39D 599
				
<p>Spacing bar Abstellbolzen Distanziale</p>	<p>Backing plate Distanzkappe Reazione per cilindro</p>	<p>Angular guide Winkelleiste Guida angolare</p>	<p>Spacer Rückfalldistanz Distanziale</p>	<p>Tie rod Druck und Zuganker Tirante</p>
<p>549</p>	<p>551</p>	<p>552</p>	<p>553</p>	<p>554</p>
39D 599	39D 599	39D 630	39D 630	39D 630
				
<p>Tie rod Druck und Zuganker Tirante</p>	<p>Tie rod Druck und Zuganker Tirante</p>	<p>Slide stop block Schieberanschlag Arresto slitta</p>	<p>Slide stop block Schieberanschlag Arresto slitta</p>	<p>Slide stop block Schieberanschlag Arresto slitta</p>
<p>554</p>	<p>555</p>	<p>555</p>	<p>556</p>	<p>556</p>
39D 638	39D 638	39D 639	39D 639	39D 639
				
<p>Air pin Druckbolzen Candela</p>	<p>Air pin Druckbolzen Candela</p>	<p>Support for sensor Lagekontrolle für Platinen Supporto sensore</p>	<p>Support for sensor Lagekontrolle für Platinen Supporto sensore</p>	<p>Gage for sensor Einweiser für Teillagekontrolle Riferimento per sensore</p>
<p>557</p>	<p>558</p>	<p>559</p>	<p>559</p>	<p>560</p>

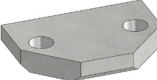
39D 649  Shim Spannschlitz Spessore 560	39D 650  Retainer bolt Haltebolzen Gruppo tirante 561	39D 651  Polyuretan spring Federblock Ammortizzatore 562	39D 807  Gage Einweiser Riferimento 562	39D 807  Precision gage Feinweiser Riferimento di precisione 563
39D 807  Gage Einweiser Riferimento 563	39D 807  Gage Einweiser Riferimento 564	39D 826  Key Passfeder Chiavetta 565	39D 828  Pad retainer Halteelement Gruppo tirante 565	39D 828  Washer Scheibe Rondella 566
39D 828  Elastomer washer Dämpfungscheibe Ammortizzatore 566	39D 828  Anti-rebound pad retainer Halteelement mit Dämpfung Gruppo tirante antirimbalo 567	39D 839  Lifting bracket with pin Tragwange mit Tragbolzen Staffa di sollevamento completa di perno 568	39D 847  Block Druckplatten für Gasdruckfedern Reazione per cilindro 569	39D 847  Block Druckplatten für Gasdruckfedern Reazione per cilindro 569
39D 851  Sliding pin Führungssäule Perno scorrevole 570	39D 851  Sliding pin Führungssäule Perno scorrevole 570	39D 854  Pad retainer pin Steckbolzen Perno di arresto 571	39D 854  Pad retainer pin Steckbolzen Perno di arresto 571	39D 854  Pad retainer pin Absteckbolzen Perno di arresto 572

<p>39D 855</p>  <p>Bush Dämpfungsbuchse Boccola</p> <p>572</p>	<p>39D 856</p>  <p>Retainer Sicherungsplatte Piastrina</p> <p>573</p>	<p>39D 860</p>  <p>Bush DIN 9834 Buchse DIN 9834 Boccola DIN 9834</p> <p>573</p>	<p>39D 861</p>  <p>Toe clamp Haltestück Ritegno per boccola</p> <p>574</p>	<p>39D 861</p>  <p>Toe clamp Haltestück Ritegno per boccola</p> <p>574</p>
<p>39D 862</p>  <p>Guide post DIN 9833 Führungssäule DIN 9833 Colonna guida DIN 9833</p> <p>575</p>	<p>39D 862</p>  <p>Guide post DIN 9833 Führungssäule DIN 9833 Colonna guida DIN 9833</p> <p>576</p>	<p>39D 863</p>  <p>Wear plate VDI 3357 Gleitplatte VDI 3357 Piastra guida VDI 3357</p> <p>577</p>	<p>39D 863</p>  <p>Wear plate VDI 3357 Gleitplatte VDI 3357 Piastra guida VDI 3357</p> <p>578</p>	<p>39D 863</p>  <p>Wear plate VDI 3357 Gleitplatte VDI 3357 Piastra guida VDI 3357</p> <p>579</p>
<p>39D 866</p>  <p>Lifting pin Tragbolzen mit Fallringsicherung Perno di sollevamento</p> <p>580</p>	<p>39D 866</p>  <p>Lifting pin Tragbolzen mit Fallringsicherung Perno di sollevamento</p> <p>581</p>	<p>39D 867</p>  <p>Bush for lifting pin Buchse für Tragbolzen Boccola per perno di sollevamento</p> <p>582</p>	<p>39D 869</p>  <p>Washer Scheibe Rondella</p> <p>583</p>	<p>39D 870</p>  <p>Air cylinder fixing Verschraubung Fissaggio cilindro</p> <p>583</p>
<p>39D 872</p>  <p>Cam roller Rollenbock Supporto con rullo</p> <p>584</p>	<p>39D 873</p>  <p>Acceleration cam Schiebervorbeschleunigung Camma di accelerazione</p> <p>585</p>	<p>39D 876</p>  <p>Lifting bracket VDI 3366 Tragzapfen VDI 336 Staffa di sollevamento VDI 336</p> <p>586</p>	<p>39D 882</p>  <p>Air cylinder fixing Ziehteilheber Fissaggio cilindro</p> <p>587</p>	<p>39D 887</p>  <p>Air cylinder adapter Teilheber Adattatore per cilindro</p> <p>587</p>

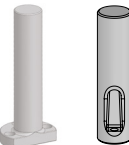
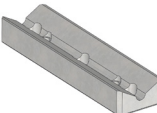
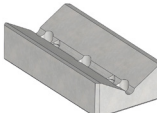
39D 887  Air cylinder adapter Teilheber Adattatore per cilindro 587	39D 890  Wear plate self-lubricating Deckleiste bronze mit festschmierstoff Piastra guida autolubrificante 588	39D 890  Wear plate Deckleiste Schieberführung Piastra guida 589	39D 890  Wear plate Deckleiste Schieberführung Piastra guida 590	39D 892  Guide bar VDI 3357 Führungsleiste VDI 3357 Lardone VDI 3357 591
39D 894  Cam dwell wear plate VDI 3357 Überlaufkeile VDI 3357 Cuneo VDI 3357 592	39D 894  Cam dwell wear plate VDI 3357 Überlaufkeile VDI 3357 Cuneo VDI 3357 593	39D 895  Balance block Enddruckplatte Distanziale di battuta 594	39D 896  Compensation pin group Ausgleichsdruckbolzen Gruppo perno di compensazione 595	39D 896  Compensation pin group Ausgleichsdruckbolzen Gruppo perno di compensazione 595
39D 896  Compensation pin group Ausgleichsdruckbolzen Gruppo perno di compensazione 596	39D 896  Compensation pin group Ausgleichsdruckbolzen Gruppo perno di compensazione 596	39D 896  Backing plate Distanzkappe Reazione per cilindro 597	39D 896  Retainer Sicherungsplatte Piastrina 597	39D 896  Retainer Sicherungsplatte Piastrina 597
39D 896  Retainer Sicherungsplatte Piastrina 598	39D 951  Air pin Unterluftbolzen Candela 599	39D 951  Air pin Unterluftbolzen Candela 600	39D 952  "V" driver VDI 3357 Prismenführung VDI 3357 Guida a "V" VDI 3357 601	39D 952  "V" driver VDI 3357 Prismenführung VDI 3357 Guida a "V" VDI 3357 601

<p>39D 952</p>  <p>"V" driver VDI 3357 Prismenführung mit festschmierstoff VDI 3357 Guida a "V" VDI 3357</p> <p>602</p>	<p>39D 952</p>  <p>"V" driver VDI 3357 Prismenführung mit festschmierstoff VDI 3357 Guida a "V" VDI 3357</p> <p>602</p>	<p>39D 954</p>  <p>Wear plate VDI 3357 Gleitplatte VDI 3357 Piastra guida VDI 3357</p> <p>603</p>	<p>39D 954</p>  <p>Wear plate VDI 3357 Gleitplatte VDI 3357 Piastra guida VDI 3357</p> <p>604</p>	<p>39D 954</p>  <p>Wear plate VDI 3357 Gleitplatte VDI 3357 Piastra guida VDI 3357</p> <p>605</p>
<p>39D 956</p>  <p>Guide bush Führungsbuchse Boccola autolubrificante</p> <p>606</p>	<p>39D 958</p>  <p>Stop pin Haltebolzen Perno di arresto</p> <p>606</p>	<p>39D 969</p>  <p>Guide post DIN 9833 Führungssäule DIN 9833 Colonna guida tipo DIN 9833</p> <p>607</p>	<p>39D 972</p>  <p>Lifter Federbolzen Sollevatore</p> <p>608</p>	<p>39D 976</p>  <p>Spacer plate toothed Distanzplatte gezahnt Tassello di compensazione</p> <p>609</p>
<p>39D 993</p>  <p>Plate for sensor Halterung Piastrina portasensore</p> <p>610</p>	<p>39D 995</p>  <p>Spacer Distanzstück Distanziale</p> <p>610</p>	<p>39D 995</p>  <p>Washer/stop block Scheibe/halteplatte Rondella/tassello</p> <p>611</p>	<p>39D 995</p>  <p>Retainer pin Ziehteilheber Perno con rondella</p> <p>611</p>	<p>39D 1392</p>  <p>Distributor Verteilerblocke Distributore</p> <p>612</p>
<p>39D 1430</p>  <p>Distributor Verteilerblocke Distributore</p> <p>612</p>	<p>39D 1497</p>  <p>Distributor Verteilerblocke Distributore</p> <p>612</p>	<p>39V 863</p>  <p>Visual locator setting punch Stempel f. entgasungsnoppen Punzone di visualizzazione</p> <p>613</p>	<p>39V 1071</p>  <p>Threaded bush Genwindebuchse Boccola filettata</p> <p>613</p>	<p>39V 1159</p>  <p>Gib VDI 3387 Führungslasche VDI 3387 Guida VDI 3387</p> <p>614</p>

39V 1162	39V 1162	39V 1168	39V 1176	39V 1178
				
Stop block Abstandsblock Distanziale	Stop block Abstandsblock Distanziale	Locating cone Kegeldistanz Cono di centraggio	Coil spring Schraubenfedern Molla a filo	Stripper for blanking dies Abstreifer für Platinenschnitte Estrattore per stampi
615	615	616	617	618
39V 1199	39V 1205	39V 1234	39V 1242	39V 1254
		 RANGE EXTENSION		
Lifting pin VDI 3366 Tragschraube VDI 3366 Perno di sollevamento VDI 3366	Locating pin Zentrierbolzen Centraggio	Ejector Abdrückstift Espulsore	Gage Einweiser Riferimento	Locating block Fangbacke Tassello di centraggio
619	619	620	621	621
39V 1304	39V 1304	39V 1569	39V 1569	39V 1569
				
Key Passfeder Chiavetta	Key Passfeder Chiavetta	Roller stock lifter Federnde laufrolle Rullino sollevamento nastro	Roller stock lifter Federnde laufrolle Rullino sollevamento nastro	Roller stock lifter Federnde laufrolle Rullino sollevamento nastro
622	622	623	624	625
39D 22047				
				
Gage with position control Klappenweiser mit Lagekontrolle Riferimento con controllo di posizione				
626				

SLEEVE - FÜHRUNGSEINHEIT - CANOTTO GUIDA

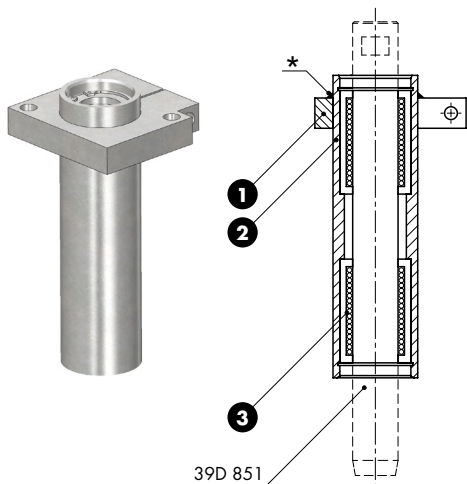

Notes

- 1 Material: St37
- 2 Material: CK45
- 3 Linear ball bearing



* Fixing at assembly with 3 spot welding
Bei der montage mit schweißpunkten befestigen
Fissare al montaggio con tre punti di saldatura

ORDER EXAMPLE	VW CODE
	39D 506/10
VW CODE	
39D 506/10	

GAGE - EINWEISER - RIFERIMENTO

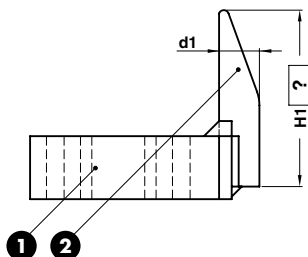
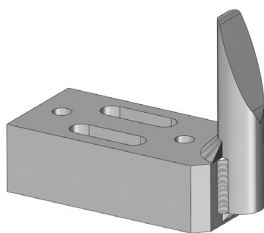

Notes

- 1 Material: St37
- 2 Material: CK15 - HRC: 58÷60

Only for replacement
Nur für Reparatur
Solo per riparazione



ORDER EXAMPLE	VW CODE	H1=200
	39D 528/3	200
VW CODE		d1
39D 528/1		16
39D 528/2		20
39D 528/3		25

BRACE - VERLASCHUNG - BRETELLA

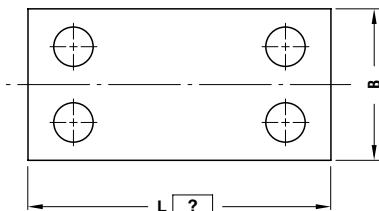
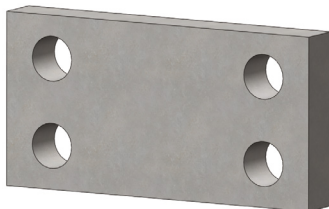

Notes

Material: CK45



ORDER EXAMPLE	VW CODE	L=200
	39D 543/2	200

VW CODE	B
39D 543/1	80
39D 543/2	100

Standard VW/Audi

39D 571

TIE ROD - FÜHRUNGSBOLZEN - TIRANTE

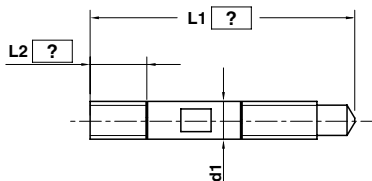
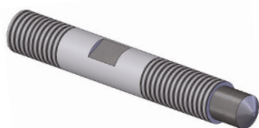

Notes

Material: 9SMn28



ORDER EXAMPLE	VW CODE	L1=300	L2=100
	39D 571/13	300	100

VW CODE	d1
39D 571/10	10
39D 571/13	13
39D 571/16	16
39D 571/20	20

SPACING BAR - ABSTELLBOLZEN - DISTANZIALE

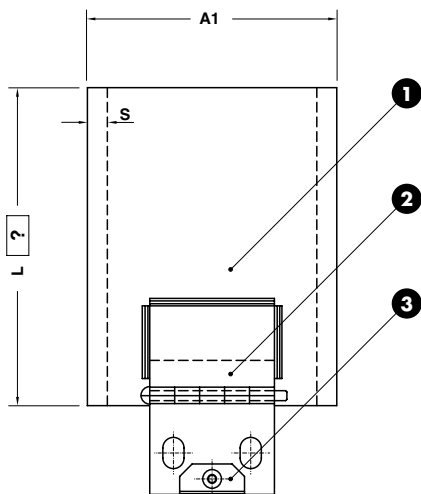
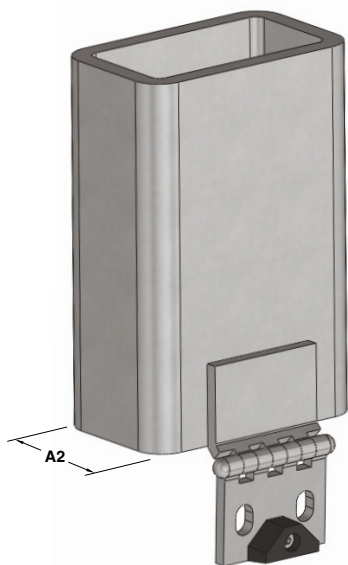

80 < L < 400

Notes

- 1 **Material:** St37
- 2 AHA Hinge***
- 3 **Material:** Elastomer 68SH

Only for replacement
Nur für Reparatur
Solo per riparazione



* To storage dies without gas springs
Zum Abstellen von Presswerkzeugen ohne Gasdruckfedern
Per il deposito di stampi senza molla a gas

** To storage dies with gas springs
Zum Abstellen von Presswerkzeugen mit Gasdruckfedern
Per il deposito di stampi con molla a gas

*** Scharnier
Cerniera

ORDER EXAMPLE	VW CODE	L=150
	39D 578/30	150

VW CODE	A1	A2	S
39D 578/30*	100	60	7-8
39D 578/40**	70	50	3

SPACING BAR - ABSTELLBOLZEN - DISTANZIALE

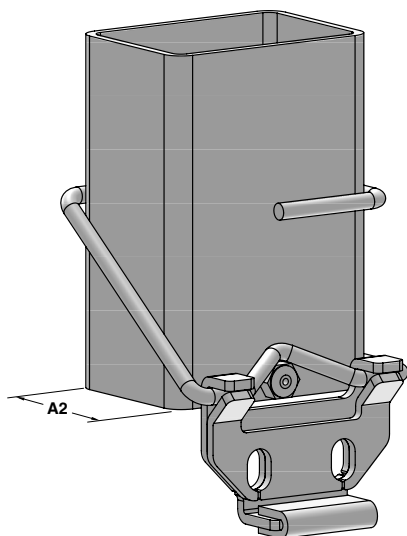

⚠

80 < L < 400

- Notes**
- 1** Material: St37
 - 2** Steel spring
 - 3** Rivet
 - 4** Plate
 - 5** Plate
 - 6** PVC



Standard VW/Audi

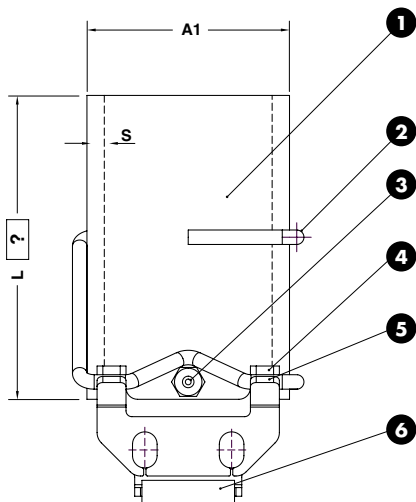

ORDER EXAMPLE	VW CODE	L=150	
	39D 578/70	150	
VW CODE	A1	A2	S
39D 578/70	70	50	5
39D 578/80	70	50	3

SPACING BAR - ABSTELLBOLZEN - DISTANZIALE

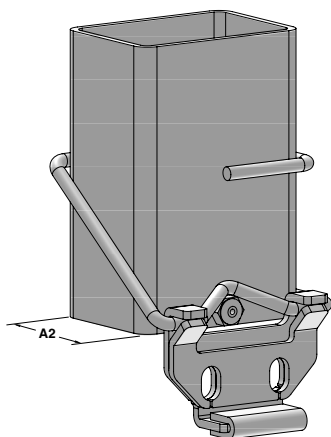

Notes

- 1 Material: St37
- 2 Steel spring
- 3 Rivet
- 4 Plate
- 5 Plate
- 6 PVC



ONLY FOR CODE 71-81

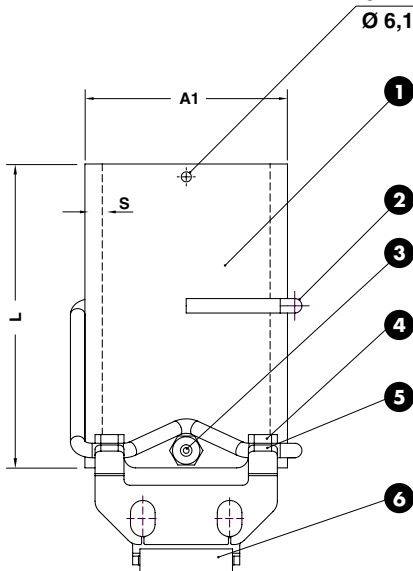

ORDER EXAMPLE 	VW CODE			
	39D 578/71			

VW CODE	L	A1	A2	S
39D 578/71	480	70	50	5
39D 578/81	480	70	50	3
39D 578/82	215	70	50	3

BACKING PLATE - DISTANZKAPPE - REAZIONE PER CILINDRO

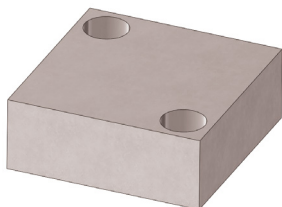

Notes

Material: 16MnCr5 - **HRC:** 60÷62
 Only for replacement
 Nur für Reparatur
 Solo per riparazione

STOCK



VW CODE
 39D 578/2

VW CODE

39D 578/2

BACKING PLATE - DISTANZKAPPE - REAZIONE PER CILINDRO

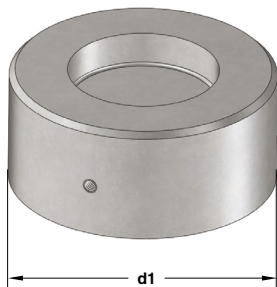

Notes

Material: CK45

STOCK



VW CODE
 39D 578/56

VW CODE**d1**

39D 578/55

90

39D 578/56

100

BACKING PLATE - DISTANZKAPPE - REAZIONE PER CILINDRO

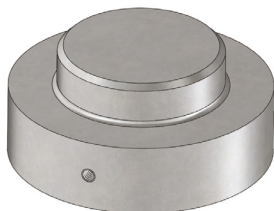

Notes

Material: CK45

STOCK



VW CODE
 39D 578/65

VW CODE

39D 578/65

ANGULAR GUIDE - WINKELLEISTE - GUIDA ANGOLARE

Notes

Material: Bronze + Graphite
HB > 190

STOCK

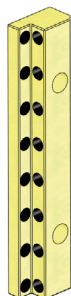

FORM A

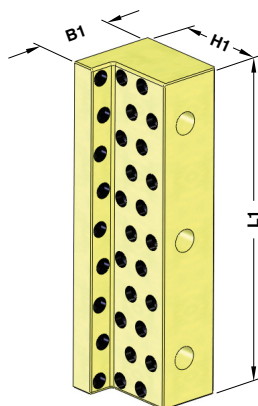

FORM B

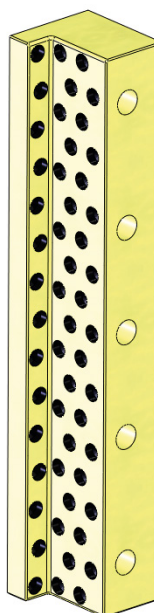

FORM C

	VW CODE
	39D 582/1

VW CODE	L1	B1	H1	FORM	VW CODE	L1	B1	H1	FORM
39D 582/1	125	25	15	A	39D 582/12	200	70	75	A
39D 582/2	160	25	15	A	39D 582/13	250	70	75	B
39D 582/3	125	32	30	A	39D 582/15	400	70	75	C
39D 582/4	160	32	30	A	39D 582/16	160	85	90	A
39D 582/5	200	32	30	A	39D 582/17	200	85	90	A
39D 582/6	100	55	55	A	39D 582/18	250	85	90	B
39D 582/7	160	55	55	A	39D 582/20	400	85	90	C
39D 582/11	160	70	75	A					

SPACER - RÜCKFALLDISTANZ - DISTANZIALE

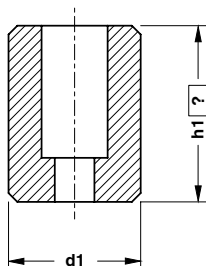

Notes
Material: CK45



	VW CODE	h1=30
	39D 592/11	30
VW CODE		d1
39D 592/10	25	
39D 592/11	30	
39D 592/12	40	
39D 592/13	50	

Standard VW/Audi

TIE ROD - DRUCK UND ZUGANKER - TIRANTE

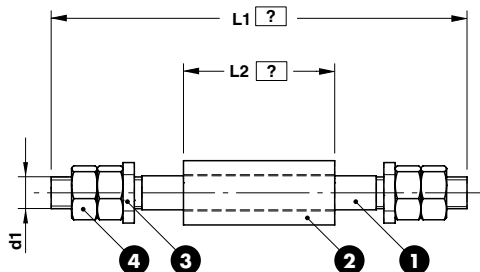

Notes

- 1 Material: 34Cr4
- 2 Material: St37
- 3 Material: CK45
- 4 DIN 934



ORDER EXAMPLE	VW CODE	L1=550	L2=200
	39D 599/1	550	200

VW CODE	d1
39D 599/1	M42x1,5

TIE ROD - DRUCK UND ZUGANKER - TIRANTE

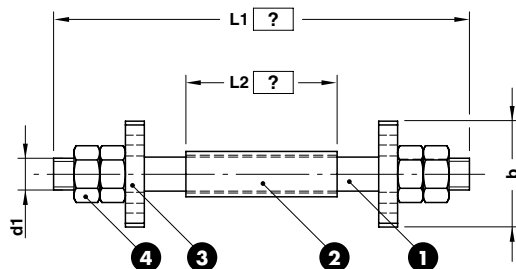
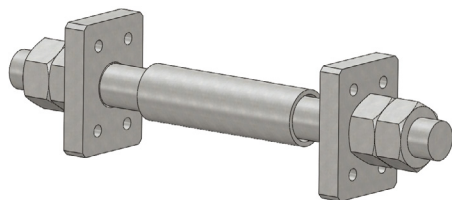

Notes

- 1 Material: 34Cr4
- 2 Material: St37
- 3 Material: CK45
- 4 DIN 934



ORDER EXAMPLE	VW CODE	L1=550	L2=200
	39D 599/2B	550	200

VW CODE	b	d1
39D 599/2	140	M42x1,5
39D 599/5	160	M42x1,5

TIE ROD - DRUCK UND ZUGANKER - TIRANTE

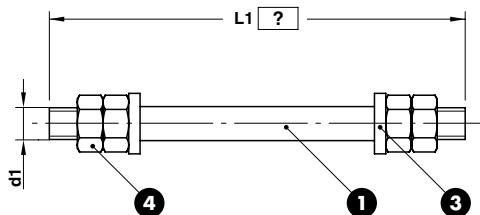

Notes

- 1 Material:** 34Cr4
- 3 Material:** CK45
- 4** DIN 934



ORDER EXAMPLE	VW CODE	L1=550
	39D 599/3	550
VW CODE		d1
39D 599/3		M42 x 1.5
39D 599/4		M56 x 1.5

Standard VW/Audi

SLIDE STOP BLOCK - SCHIEBERANSCHLAG - ARRESTO SLITTA

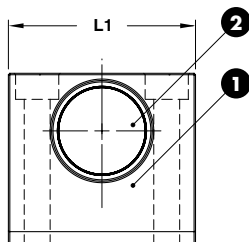
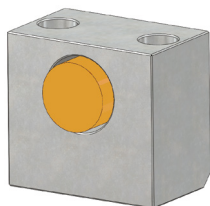

Notes

- 1 Material:** CK45
- 2 Material:** Elastomer 90 SH

Only for replacement
Nur für Reparatur
Solo per riparazione



ORDER EXAMPLE	VW CODE	
	39D 630/8	
VW CODE		L1
39D 630/8		65
39D 630/10		75

SLIDE STOP BLOCK - SCHIEBERANSCHLAG - ARRESTO SLITTA

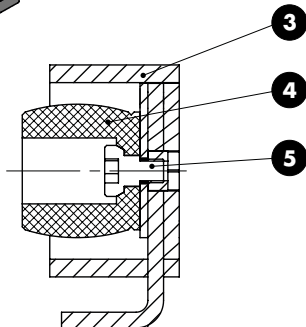
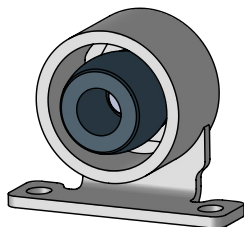

Notes

- 3** Material: St37
- 4** Material: CO-Polyester Elastomer
- 5** M6x12 DIN 912

STOCK

ORDER
EXAMPLE

VW CODE

39D 630/22

VW CODE

39D 630/22

SLIDE STOP BLOCK - SCHIEBERRANSCHLAG - ARRESTO SLITTA

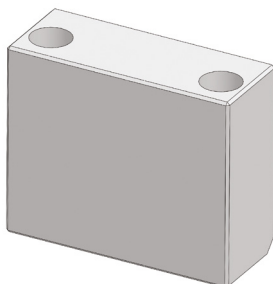

Notes

Material: CK45

Only for replacement
Nur für Reparatur
Solo per riparazione

STOCK

ORDER
EXAMPLE

VW CODE

39D 630/25

VW CODE

39D 630/21

39D 630/25

AIR PIN - DRUCKBOLZEN - CANDELA



39D 638/2

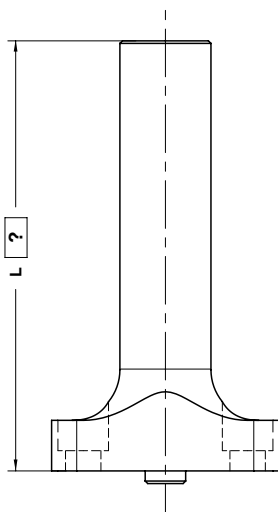

L max = 360

Notes

Material: CK45 - 800÷1000 N/mm²

Only for replacement

Nur für Reparatur

Solo per riparazione



VW CODE

L=150

39D 638/3

150

VW CODE

39D 638/2

39D 638/3

39D 638/4

39D 638/5



39D 638/3



39D 638/4





39D 638/5

AIR PIN - DRUCKBOLZEN - CANDELA

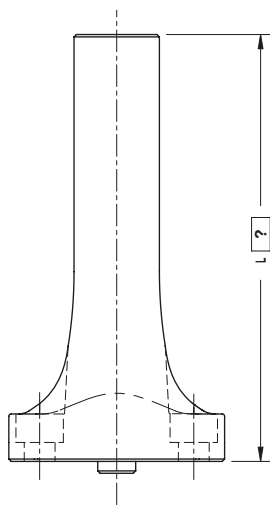

39D 638/10



L max = 360

Notes
Material: C45 - 800÷1000 N/mm²



39D 638/11



39D 638/12

	VW CODE	L=150
	39D 638/11	150

VW CODE	
39D 638/10	
39D 638/11	
39D 638/12	

SUPPORT FOR SENSOR - LAGEKONTROLLE FÜR PLATINEN - SUPPORTO SENSORE

* As shown in drawing
Gemäß zeichnung
Come a disegno

** Opposite to drawing
Spiegelverkehrt
Opposto al disegno

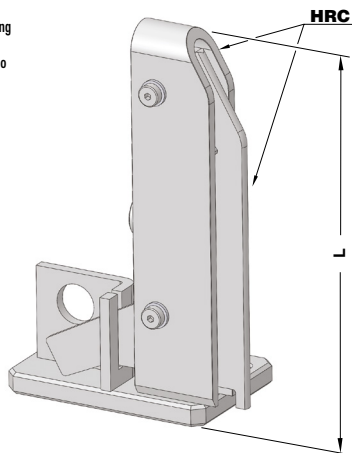

STOCK

Notes

Material: Steel - **HRC:** 58÷60

Only for replacement
Nur für Reparatur
Solo per riparazione



VW CODE

39D 639/3

VW CODE	L	SIDE
39D 639/1	145	LEFT**
39D 639/2	145	RIGHT*
39D 639/3	185	LEFT **
39D 639/4	185	RIGHT*
39D 639/25	225	LEFT **
39D 639/26	225	RIGHT*
39D 639/30	145	LEFT**
39D 639/31	145	RIGHT*
39D 639/32	185	LEFT **
39D 639/33	185	RIGHT*
39D 639/34	225	LEFT **
39D 639/35	225	RIGHT*

Standard VW/Audi

SUPPORT FOR SENSOR - LAGEKONTROLLE FÜR PLATINEN - SUPPORTO SENSORE

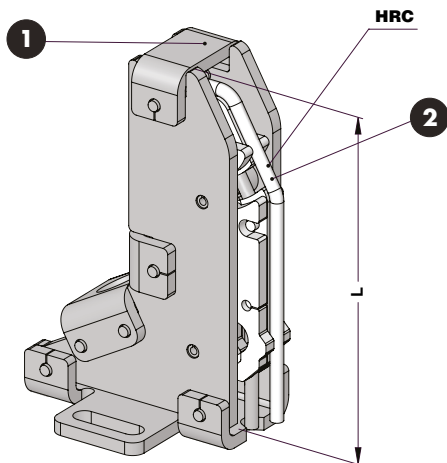

Notes

1 Material: Si37

2 Material: Steel HRC:40-45

STOCK



VW CODE

39D 639/40

VW CODE	L
39D 639/40	145
39D 639/41	185
39D 639/42	225

GAGE FOR SENSOR - EINWEISER FÜR TEILLAGEKONTOLLE - RIFERIMENTO PER SENSORE

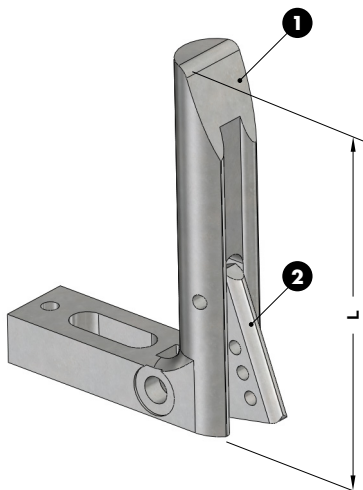

Notes

① Material: CK60

② Material: St37



VW CODE

39D 639/22

VW CODE	L
39D 639/20	120
39D 639/21	150
39D 639/22	180
39D 639/23	250

SHIM - SPANNSCHLITZ - SPESSORE

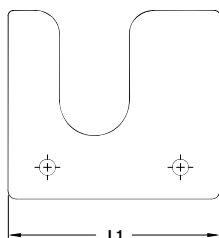
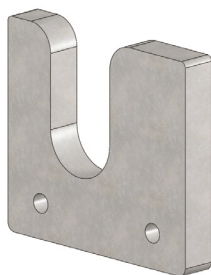

Notes

Material: St52

STOCK



VW CODE

39D 649/2

VW CODE	L1
39D 649/1	110
39D 649/2	135
39D 649/3	185
39D 649/4	160

RETAINER BOLT - HALTEBOLZEN - GRUPPO TIRANTE

Notes

- 1 3 Material:** 42CrMo4
- 2 4 Material:** CK45
- 5 Material:** Elastomer Black 68 SH
Elastomer Red 90 SH
- 6 Split Pin** DIN EN ISO 1234

Only for replacement
Nur für Reparatur
Solo per riparazione

Respect the max. load
Maximale Nutzlast beachten
Rispettare il carico max.



39D 650/31÷38

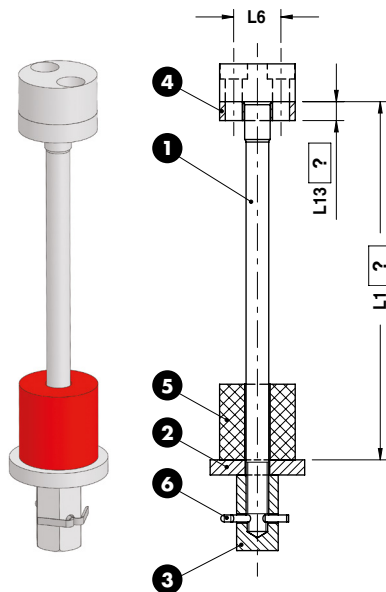

39D 650/51÷58

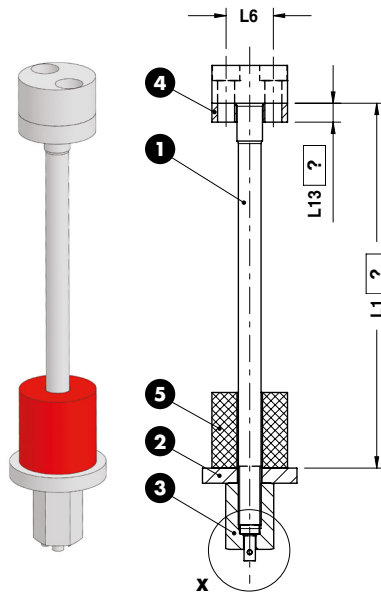

*Max. capacity load
Belastbarkeit max.
Portata massima

**Optional washer, L13=?
Scheibe optionalis, L13=?
Rondella opzionale, L13=?

ORDER EXAMPLE	VW CODE	L1=190	L13=10**
	39D 650/32	190	10

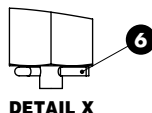

VW CODE	L6	MCL*(N)	Elastomer Shore (SH)	VW CODE	L6	MCL*(N)	Elastomer Shore (SH)
39D 650/31	25	15000	68	39D 650/51	25	15000	68
39D 650/32	30	25000	68	39D 650/52	30	25000	68
39D 650/33	30	25000	68	39D 650/53	30	25000	68
39D 650/34	34	45000	68	39D 650/54	34	45000	68
39D 650/35	25	15000	90	39D 650/55	25	15000	90
39D 650/36	30	25000	90	39D 650/56	30	25000	90
39D 650/37	30	25000	90	39D 650/57	30	25000	90
39D 650/38	34	45000	90	39D 650/58	34	45000	90

Standard VW/Audi

POLYURETAN SPRING - FEDERBLOCK - AMMORTIZZATORE

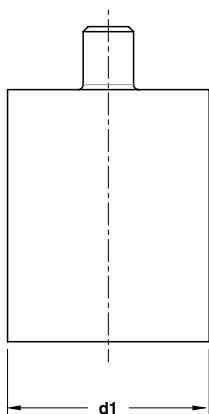

Notes

Material: Elastomer 92 SH

STOCK



VW CODE

39D 651/2

VW CODE	d1
39D 651/1	63
39D 651/2	80
39D 651/3	100
39D 651/4	125

GAGE - EINWEISER - RIFERIMENTO

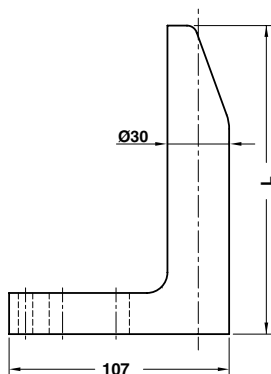
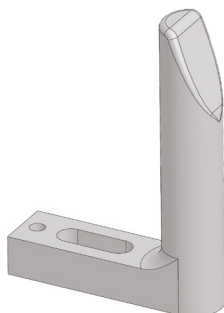

Notes

Material: CK60

STOCK



VW CODE

39D 807/1 L=90

VW CODE	L
39D 807/1 L=65	65
39D 807/1 L=90	90
39D 807/1 L=120	120
39D 807/1 L=150	150
39D 807/1 L=180	180
39D 807/1 L=250	250
39D 807/1 L=300	300
39D 807/1 L=350	350

PRECISION GAGE - FEINENWEISER - RIFERIMENTO DI PRECISIONE

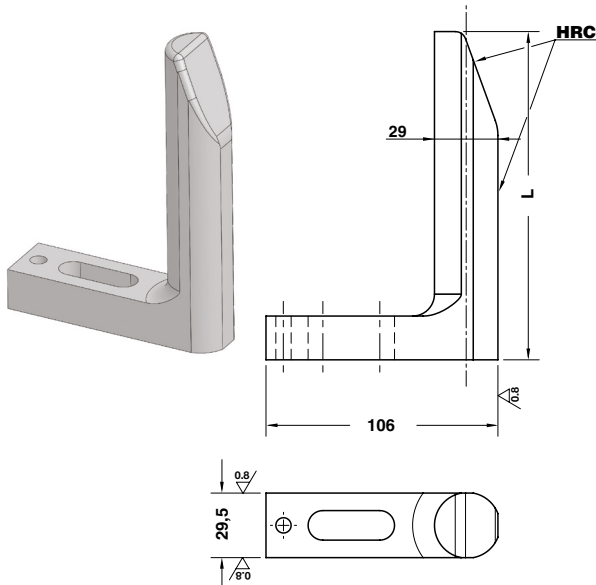

Notes
Material: CK60 - HRC: 58÷60

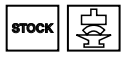

ORDER EXAMPLE	VW CODE
	39D 807/2 L=90

VW CODE	L
39D 807/2 L=65	65
39D 807/2 L=90	90
39D 807/2 L=120	120
39D 807/2 L=150	150
39D 807/2 L=180	180
39D 807/2 L=250	250
39D 807/2 L=300	300
39D 807/2 L=350	350

Standard VW/Audi

GAGE HARDENED - EINWEISER GEHÄRTET - RIFERIMENTO INDURITO

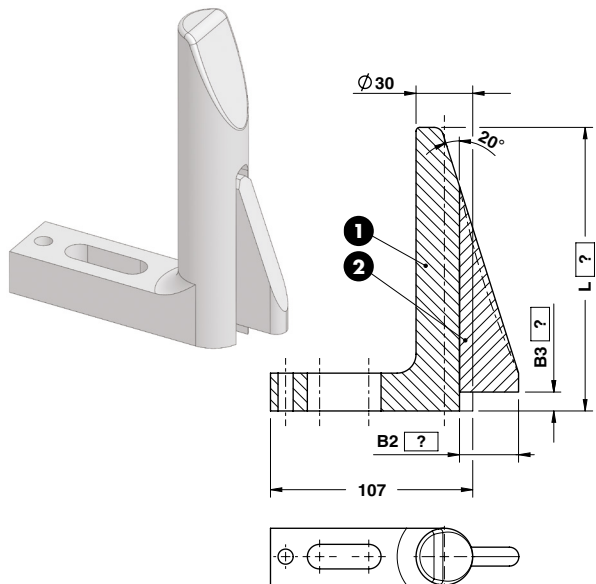

Notes
1 2
Material: CK60 - HRC: 58÷60

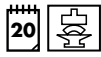

ORDER EXAMPLE	VW CODE	L=90	B2=20	B3=5
	39D 807/3	90	20	5

VW CODE	L
39D 807/3	≥ 65 - 350

GAGE HARDENED - EINWEISER GEHÄRTET - RIFERIMENTO INDURITO

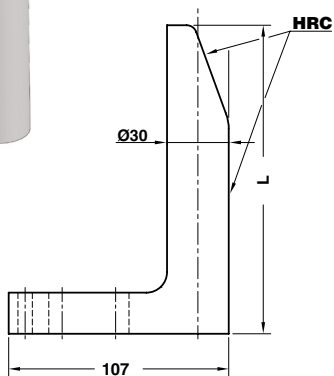
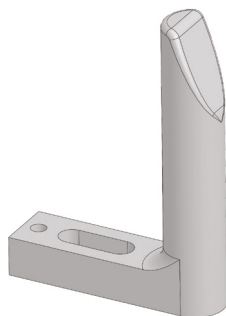

Notes

Material: CK60 - **HRC:** 58÷60

STOCK



VW CODE	
39D 807/4 L=90	

VW CODE	L
39D 807/4 L=65	65
39D 807/4 L=90	90
39D 807/4 L=120	120
39D 807/4 L=150	180
39D 807/4 L=180	150
39D 807/4 L=250	250
39D 807/4 L=300	300
39D 807/4 L=350	350

KEY - PASSFEDER - CHIAVETTA

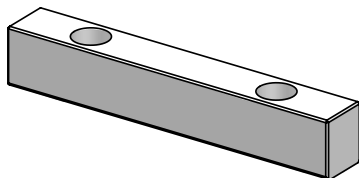

39D 826/1

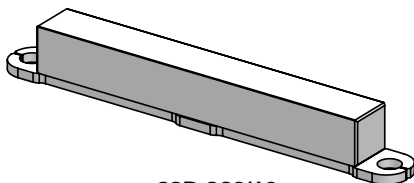

39D 826/10

Notes

Material: CK45+C

STOCK



VW CODE
39D 826/1

VW CODE

39D 826/1
39D 826/10

Standard VW/Audi

PAD RETAINER - HALTEELEMENT - GRUPPO TIRANTE

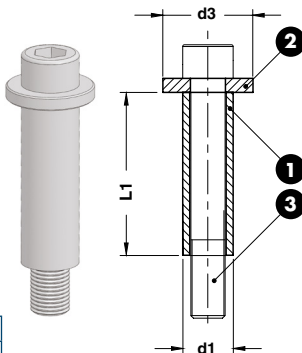

Notes

- 1** Material: Si37
- 2** Material: CK45
- 3** DIN 912 cl. 8.8

STOCK



VW CODE
39D 828/5

VW CODE	d1 x L1	d3	Screw DIN 912 cl. 8.8	VW CODE	d1 x L1	d3	Screw DIN 912 cl. 8.8	VW CODE	d1 x L1	d3	Screw DIN 912 cl. 8.8
39D 828/4	16 x 40	25	M10x60	39D 828/12	20 x 100	30	M12x130	39D 828/20	36 x 80	55	M24x130
39D 828/5	16 x 50	25	M10x70	39D 828/13	25 x 63	38	M16x100	39D 828/21	36 x 100	55	M24x150
39D 828/6	16 x 63	25	M10x90	39D 828/14	25 x 80	38	M16x110	39D 828/22	36 x 125	55	M24x180
39D 828/8	16 x 100	25	M10x120	39D 828/15	25 x 100	38	M16x130	39D 828/23	42 x 80	65	M30x140
39D 828/9	20 x 50	30	M12x80	39D 828/16	25 x 125	38	M16x160	39D 828/24	42 x 100	65	M30x160
39D 828/10	20 x 63	30	M12x90	39D 828/17	30 x 80	45	M20x120	39D 828/25	42 x 125	65	M30x200
39D 828/11	20 x 80	30	M12x110	39D 828/19	30 x 125	45	M20x180				

WASHER - SCHEIBE - RONDELLA

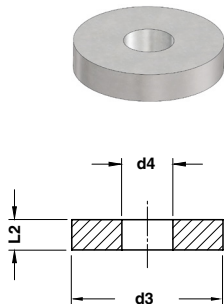

Notes

Material: CK45

STOCK



VW CODE

39D 828/42

VW CODE	d3	d4	L2
39D 828/41	25	10,5	5
39D 828/42	30	13,2	5
39D 828/43	38	17,0	6
39D 828/44	45	21,0	8
39D 828/45	55	25,0	10
39D 828/46	30	10,5	5
39D 828/47	35	13,0	5
39D 828/48	50	17,0	6
39D 828/49	65	21,0	8
39D 828/50	70	25,0	10
39D 828/57	65	32,0	15
39D 828/58	90	32,0	15

39D 828

ELASTOMER WASHER - DÄMPFUNGSCHEIBE - AMMORTIZZATORE

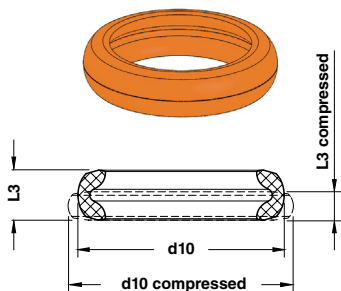

Notes

Material: CO-Polyester Elastomer

STOCK

*Die höchste Belastung
Carico massimo ammissibile

**Komprimiert
Compresso



VW CODE

39D 828/52

VW CODE	d10	d10 (compressed**)	L3	L3 (compressed**)	Shore	Load* (N)
39D 828/51	26,2	28,4	7,8 ±0,3	5,5 ±0,3	55D	5500
39D 828/52	32,1	35,1	10,8 ±0,3	6,0 ±0,3	72D	9000
39D 828/53	46,3	49,8	17,0 ±0,4	11,6 ±0,3	72D	20000
39D 828/54	54,6	61,8	21,3 ±0,4	13,0 ±0,3	55D	30000
39D 828/55	61,8	69,9	21,5 ±0,4	13,2 ±0,3	55D	46000
39D 828/56	78,2	89,0	29,8 ±0,5	17,9 ±0,3	55D	75000

ANTI-REBOUND PAD RETAINER HALTELEMENT MIT DÄMPFUNG GRUPPO TIRANTE ANTIRIMBALZO

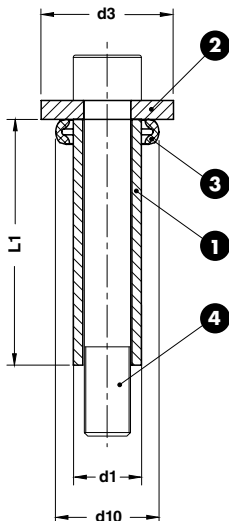

Notes

- 1** Material: Si37
- 2** Material: CK45
- 3** Material: CO-Polyester Elastomer
- 4** DIN 912 cl. 8.8

STOCK



Standard VW/Audi



VW CODE

39D 828/74

VW CODE	d1 x L1	d3	d10	Screw DIN 912 cl. 8.8	Shore	VW CODE	d1 x L1	d3	d10	Screw DIN 912 cl. 8.8	Shore
39D 828/73	16 x 40	30	26,2	M10x60	55D	39D 828/84	25 x 100	50	46,3	M16x130	72D
39D 828/74	16 x 50	30	26,2	M10x70	55D	39D 828/85	25 x 125	50	46,3	M16x160	72D
39D 828/75	16 x 63	30	26,2	M10x90	55D	39D 828/86	30 x 80	65	54,6	M20x120	55D
39D 828/77	16 x 100	30	26,2	M10x120	55D	39D 828/88	30 x 125	65	54,6	M20x180	55D
39D 828/78	20 x 50	35	32,1	M12x80	72D	39D 828/89	36 x 80	70	61,8	M24x130	55D
39D 828/79	20 x 63	35	32,1	M12x90	72D	39D 828/90	36 x 100	70	61,8	M24x150	55D
39D 828/80	20 x 80	35	32,1	M12x110	72D	39D 828/91	36 x 125	70	61,8	M24x180	55D
39D 828/81	20 x 100	35	32,1	M12x130	72D	39D 828/92	42 x 80	90	78,2	M30x140	55D
39D 828/82	25 x 63	50	46,3	M16x100	72D	39D 828/93	42 x 100	90	78,2	M30x160	55D
39D 828/83	25 x 80	50	46,3	M16x110	72D	39D 828/94	42 x 125	90	78,2	M30x200	55D

LIFTING BRACKET WITH PIN AND LOCATING PINS
TRAGWANGE MIT TRAGBOLZEN UND ZENTRIERBOLZEN
STAFFA DI SOLLEVAMENTO COMPLETA DI PERNO E CENTRAGGI

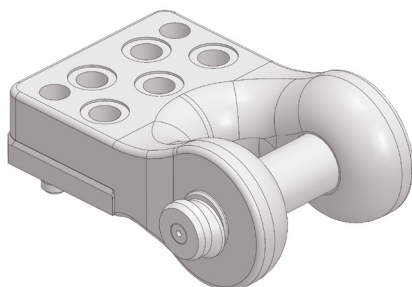
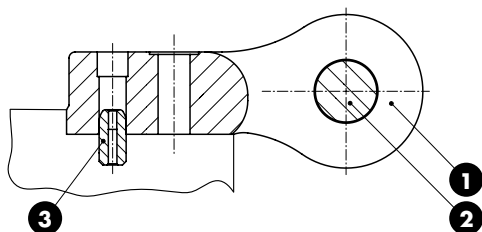

FORM A

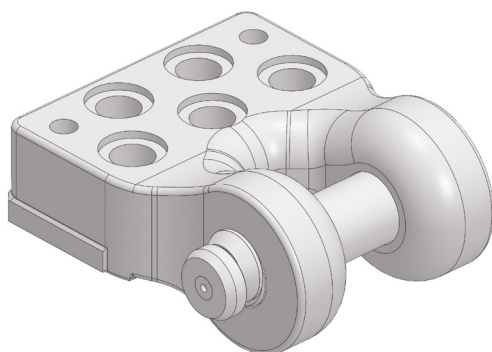

FORM B



Respect the max load
 Maximale Nutzlast beachten
 Rispettare il carico Max

WARNING - ACHTUNG - ATTENZIONE:
 For safety reason, please consider always that the weight of the die has to be supported by just 2 lifting brackets.

Aus Sicherheitsgründen stets berücksichtigen, dass zwei Tragwagen das gesamte Werkzeuggewicht tragen müssen.

Per ragioni di sicurezza, considerare sempre che il peso dello stampo deve essere sopportato da 2 sole staffe.

Notes

- 1 **Material:** St52
- 2 39D 866 - **Material:** CK45
- 3 39V 1205/1
Material: 16MnCr5 - **HRC:** 58÷62

Screws not included



VW CODE

39D 839/2

VW CODE	Max load (kg)	Max die weight (kg)	FORM
39D 839/1	8000	16000	A
39D 839/2	12500	25000	B

BLOCK - DRUCKPLATTEN FÜR GASDRUCKFEDERN - REAZIONE PER CILINDRO

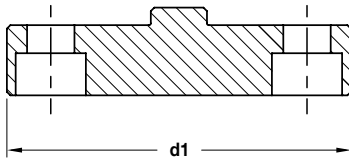

Notes

Material: 16MnCr5 - HRC: 58÷60

STOCK



VW CODE

39D 847/2

VW CODE	d1
39D 847/1	98
39D 847/2	113
39D 847/3	128
39D 847/4	143

BLOCK - DRUCKPLATTEN FÜR GASDRUCKFEDERN - REAZIONE PER CILINDRO

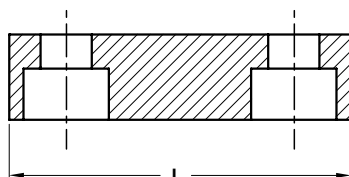
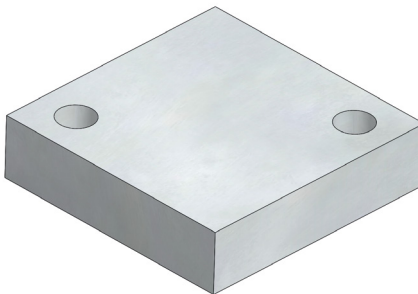

Notes

Material: 16MnCr5 - HRC: 58÷60

STOCK



VW CODE

39D 847/11

VW CODE	L
39D 847/10	40
39D 847/11	60
39D 847/12	70
39D 847/13	100
39D 847/14	140

SLIDING PIN - FÜHRUNGSSÄULE - PERNO SCORREVOLE

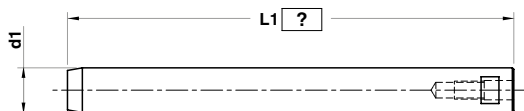

Notes

Material: CK45 - HRC: 60÷62



	VW CODE	L1=300
	39D 851/20	300

VW CODE	d1
39D 851/20	20
39D 851/25	25
39D 851/30	30

SLIDING PIN - FÜHRUNGSSÄULE - PERNO SCORREVOLE

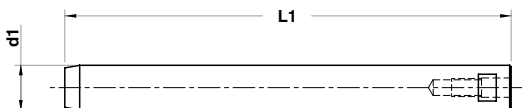

Notes

Material: CK45 - HRC: 60÷62



	VW CODE
	39D 851/32

VW CODE	d1	L1
39D 851/32	30	270
39D 851/34	30	425

PAD RETAINER PIN - STECKBOLZEN - PERNO DI ARRESTO

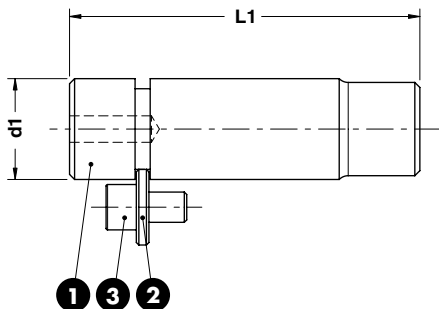
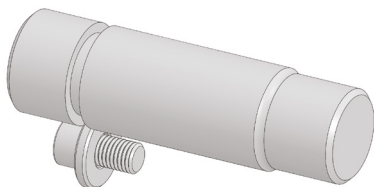

Notes

- 1 **Material:** 42CrMo4 - 1000 N/mm²
- 2 39D 828/42
- 3 DIN EN ISO 4762 M12x20



VW CODE
39D 854/2

VW CODE	d1	L1
39D 854/1	32	105
39D 854/2	32	122
39D 854/3	40	139
39D 854/4	40	159
39D 854/5	50	167
39D 854/6	50	192
39D 854/7	63	202
39D 854/8	63	237

Standard VW/Audi

PAD RETAINER PIN - STECKBOLZEN - PERNO DI ARRESTO

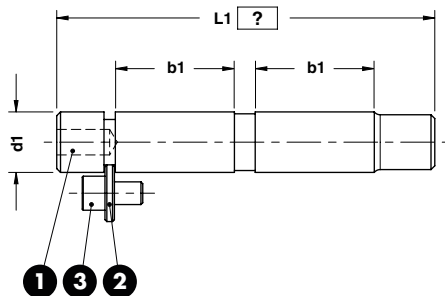
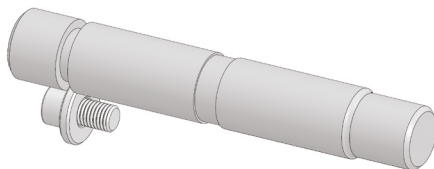

Notes

- 1 **Material:** 42CrMo4 - 1000 N/mm²
- 2 39D 828/42
- 3 DIN EN ISO 4762 M12x20



VW CODE	L1=150
39D 854/13	150

VW CODE	b1	d1
39D 854/11	63	32
39D 854/13	80	40
39D 854/15	100	50
39D 854/17	125	63
39D 854/21	80	32
39D 854/23	100	40
39D 854/25	125	50
39D 854/27	160	63

PAD RETAINER PIN - ABSTECKBOLZEN - PERNO DI ARRESTO

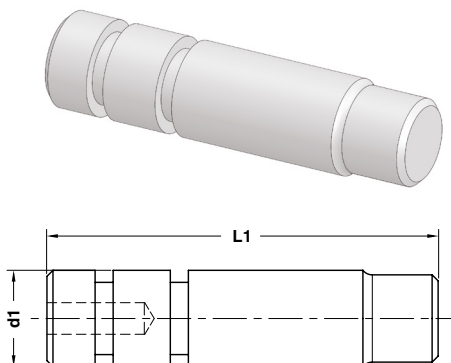

Notes

Material: 42CrMo4 - 800=1000 N/mm²

Only for replacement
Nur für Reparatur
Solo per riparazione



VW CODE

39D 854/442

VW CODE	d1	L1
39D 854/441	32	130
39D 854/442	32	147
39D 854/443	40	171
39D 854/444	40	191
39D 854/445	50	207
39D 854/446	50	232
39D 854/447	63	252
39D 854/448	63	287

BUSH - DÄMPFUNGSBUCHSE - BOCCOLA

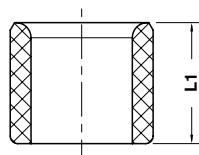
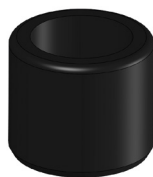

Notes

Material: Nylatron GSM P30

Only for replacement
Nur für Reparatur
Solo per riparazione



VW CODE

39D 855/5

VW CODE	L1
39D 855/4	32
39D 855/5	40
39D 855/6	50

RETAINER - SICHERUNGSPLATTE - PIASTRINA

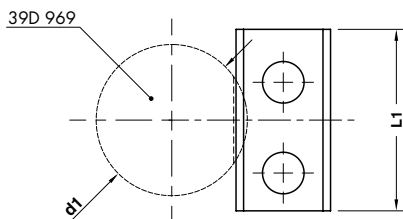
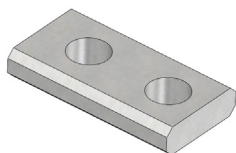

Notes

Material: St37

STOCK



VW CODE

39D 856/2

VW CODE	d1	L1
39D 856/2	25	40
	32	40
39D 856/4	40	48
	50	48
39D 856/6	63	60
	80	60

Standard VW/Audi

39D 860

BUSH SELF-LUBRICATING DIN 9834
FUHRUNGSBUCHSE DIN 9834
BOCCOLA AUTOLUBRIFICANTE DIN 9834

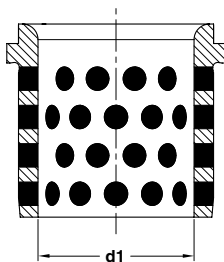

Notes

Material: Bronze + Graphite
HB > 190

STOCK



VW CODE

39D 860/32

VW CODE	d1
39D 860/31	25
39D 860/32	32
39D 860/33	40
39D 860/34	50
39D 860/35	63
39D 860/36	80
39D 860/37	100
39D 860/38	125
39D 860/40	160

TOE CLAMP - HALTESTÜCK - RITEGNO PER BOCCOLA

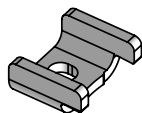

39D 861/12

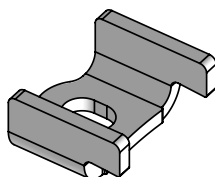

39D 861/14

Notes

Material: CK45

STOCK

Application example

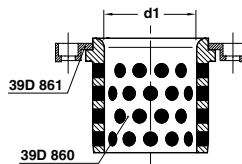

ORDER
EXAMPLE

VW CODE

39D 861/12

VW CODE

d1

39D 861/12

25-50

39D 861/14

63-160

TOE CLAMP - HALTESTÜCK - RITEGNO PER BOCCOLA

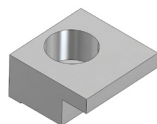

STOCK

Notes

Material: CK45

Only for replacement
Nur für Reparatur
Solo per riparazione

Application example

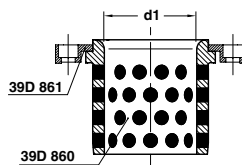

ORDER
EXAMPLE

VW CODE

39D 861/6

VW CODE

d1

39D 861/6

25-50

39D 861/10

63-160

GUIDE POST DIN 9833 - FÜHRUNGSSÄULE DIN 9833 - COLONNA GUIDA DIN 9833



Notes

Material: 16MnCr5
HRC: 60÷62

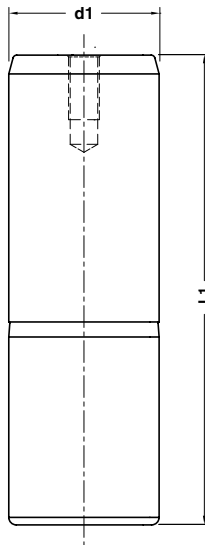

Standard VW/Audi

	VW CODE
	39D 862/47

VW CODE	d1	L1	VW CODE	d1	L1
39D 862/13	25	125	39D 862/45	50	250
39D 862/14	25	140	39D 862/46	50	280
39D 862/15	25	160	39D 862/47	50	315
39D 862/16	25	180	39D 862/48	50	355
39D 862/23	32	140	39D 862/51	63	180
39D 862/24	32	160	39D 862/52	63	200
39D 862/25	32	180	39D 862/53	63	224
39D 862/26	32	200	39D 862/54	63	250
39D 862/31	40	140	39D 862/55	63	280
39D 862/32	40	160	39D 862/56	63	315
39D 862/33	40	180	39D 862/57	63	355
39D 862/34	40	200	39D 862/58	63	400
39D 862/35	40	224	39D 862/62	80	224
39D 862/36	40	250	39D 862/63	80	250
39D 862/37	40	280	39D 862/64	80	280
39D 862/41	50	160	39D 862/65	80	315
39D 862/42	50	180	39D 862/66	80	355
39D 862/43	50	200	39D 862/67	80	400
39D 862/44	50	224			

GUIDE POST DIN 9833 - FÜHRUNGSSÄULE DIN 9833 - COLONNA GUIDA DIN 9833

Notes

Material: 16MnCr5
HRC: 60÷62

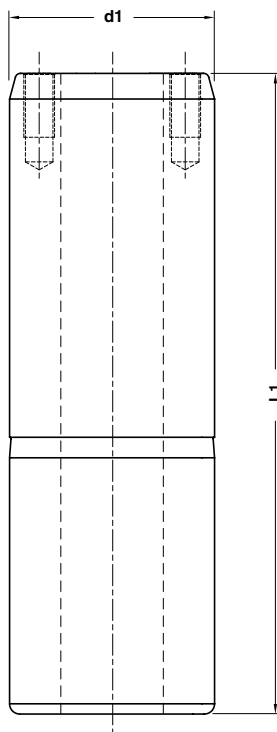

VW CODE

39D 862/75

VW CODE	d1	L1	VW CODE	d1	L1
39D 862/73	100	280	39D 862/85	125	450
39D 862/74	100	315	39D 862/86	125	500
39D 862/75	100	355	39D 862/93	160	400
39D 862/76	100	400	39D 862/94	160	450
39D 862/82	125	315	39D 862/95	160	500
39D 862/83	125	355	39D 862/96	160	560
39D 862/84	125	400			

WEAR PLATE SELF-LUBRICATING VDI 3357 GLEITPLATTE BRONZE MIT FESTSCHMIERSTOFF VDI 3357 PIASTRA GUIDA AUTOLUBRIFICANTE VDI 3357

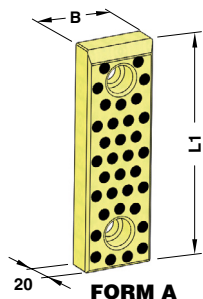

FORM A

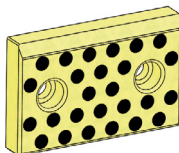

FORM B

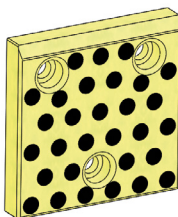

FORM C

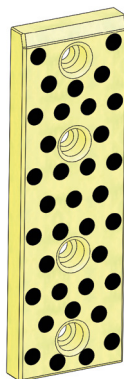

FORM D

Notes

Material: Bronze + Graphite
HB > 190

STOCK



VW CODE
39D 863/12

VW CODE	B	L1	FORM	VW CODE	B	L1	FORM	VW CODE	B	L1	FORM
39D 863/12	50	80	A	39D 863/44	125	125	C	39D 863/126	80	500	D
39D 863/13	50	100	A	39D 863/45	125	160	C	39D 863/131	100	450	D
39D 863/14	50	125	A	39D 863/46	125	200	C	39D 863/132	100	500	D
39D 863/15	50	160	A	39D 863/51	160	50	B	39D 863/141	125	450	D
39D 863/16	50	200	A	39D 863/52	160	80	B	39D 863/142	125	500	D
39D 863/21	80	50	B	39D 863/53	160	100	C	39D 863/150	100	250	D
39D 863/22	80	80	A	39D 863/54	160	125	C	39D 863/151	100	300	D
39D 863/23	80	100	A	39D 863/55	160	160	C	39D 863/152	100	350	D
39D 863/24	80	125	A	39D 863/56	160	200	C	39D 863/153	100	400	D
39D 863/25	80	160	A	39D 863/111	50	250	D	39D 863/155	125	250	D
39D 863/26	80	200	A	39D 863/112	50	300	D	39D 863/156	125	300	D
39D 863/31	100	50	B	39D 863/113	50	350	D	39D 863/157	125	350	D
39D 863/32	100	80	B	39D 863/114	50	400	D	39D 863/158	125	400	D
39D 863/33	100	100	A	39D 863/115	50	450	D	39D 863/160	160	250	D
39D 863/34	100	125	A	39D 863/116	50	500	D	39D 863/161	160	300	D
39D 863/35	100	160	A	39D 863/121	80	250	D	39D 863/162	160	350	D
39D 863/36	100	200	A	39D 863/122	80	300	D	39D 863/163	160	400	D
39D 863/41	125	50	B	39D 863/123	80	350	D	39D 863/164	160	450	D
39D 863/42	125	80	B	39D 863/124	80	400	D	39D 863/165	160	500	D
39D 863/43	125	100	C	39D 863/125	80	450	D				

WEAR PLATE STEEL VDI 3357
GLEITPLATTE STAHL VDI 3357
PIASTRA GUIDA IN ACCIAIO VDI 3357

Notes

Material: 16MnCr5
HRC: 58÷60

STOCK



FORM A

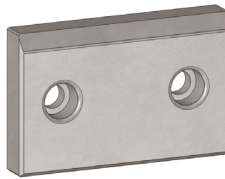

FORM B

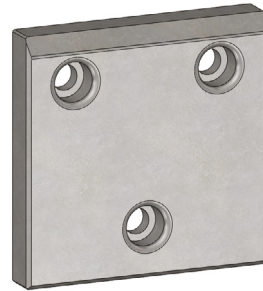

FORM C



VW CODE
39D 863/62

VW CODE	B	L1	FORM	VW CODE	B	L1	FORM	VW CODE	B	L1	FORM
39D 863/62	50	80	A	39D 863/76	80	200	A	39D 863/94	125	125	C
39D 863/63	50	100	A	39D 863/81	100	50	B	39D 863/95	125	160	C
39D 863/64	50	125	A	39D 863/82	100	80	B	39D 863/96	125	200	C
39D 863/65	50	160	A	39D 863/83	100	100	A	39D 863/101	160	50	B
39D 863/66	50	200	A	39D 863/84	100	125	A	39D 863/102	160	80	B
39D 863/71	80	50	B	39D 863/85	100	160	A	39D 863/103	160	100	C
39D 863/72	80	80	A	39D 863/86	100	200	A	39D 863/104	160	125	C
39D 863/73	80	100	A	39D 863/91	125	50	B	39D 863/105	160	160	C
39D 863/74	80	125	A	39D 863/92	125	80	B	39D 863/106	160	200	C
39D 863/75	80	160	A	39D 863/93	125	100	C				

SINTERED STEEL WEAR PLATE TYPE VDI 3357
GLEITPLATTE STAHL MIT SINTERGLEITFLÄCHE TIP VDI 3357
PIASTRA GUIDA IN ACCIAIO SINTERIZZATO TIPO VDI 3357

Notes

Material: Syntered metal

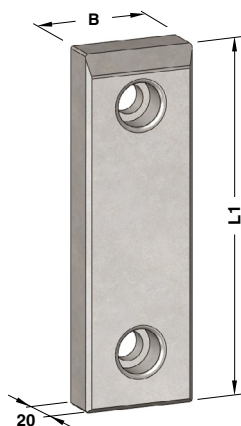

FORM A

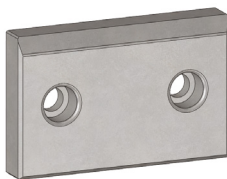

FORM B

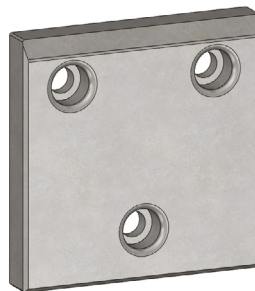

FORM C

Standard VW/Audi

	VW CODE
	39D 863/201

VW CODE	B	L1	FORM	VW CODE	B	L1	FORM	VW CODE	B	L1	FORM
39D 863/200	50	80	A	39D 863/210	80	200	A	39D 863/220	125	125	C
39D 863/201	50	100	A	39D 863/211	100	50	B	39D 863/221	125	160	C
39D 863/202	50	125	A	39D 863/212	100	80	B	39D 863/222	125	200	C
39D 863/203	50	160	A	39D 863/213	100	100	A	39D 863/223	160	50	B
39D 863/204	50	200	A	39D 863/214	100	125	A	39D 863/224	160	80	B
39D 863/205	80	50	B	39D 863/215	100	160	A	39D 863/225	160	100	C
39D 863/206	80	80	A	39D 863/216	100	200	A	39D 863/226	160	125	C
39D 863/207	80	100	A	39D 863/217	125	50	B	39D 863/227	160	160	C
39D 863/208	80	125	A	39D 863/218	125	80	B	39D 863/228	160	200	C
39D 863/209	80	160	A	39D 863/219	125	100	C				

LIFTING PIN - TRAGBOLZEN MIT FALLRINGSICHERUNG - PERNO DI SOLLEVAMENTO



Respect the max load
Maximale Nutzlast beachten
Rispettare il carico Max

WARNING - ACHTUNG - ATTENZIONE:

For safety reason, please consider always that the weight of the die has to be supported by just 2 lifting pins.

Aus Sicherheitsgründen stets berücksichtigen, dass zwei Tragbolzen das gesamte Werkzeuggewicht tragen müssen.

Per ragioni di sicurezza, considerare sempre che il peso dello stampo deve essere sopportato da 2 soli perni.

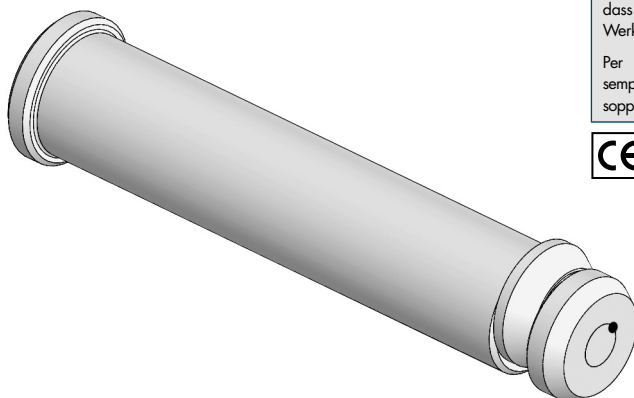

Security pin

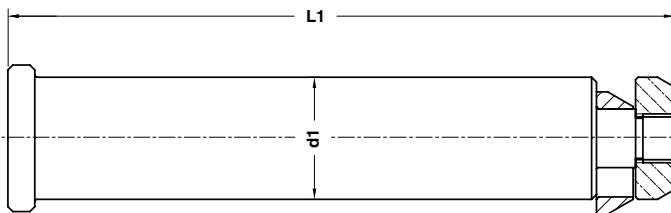
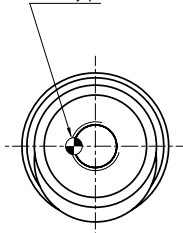

ORDER EXAMPLE	VW CODE
	39D 866/4

VW CODE	Max load (kg)	Max die weight (kg)	L1	d1	Material
39D 866/3	3200	6400	175	32	CK45
39D 866/4	5000	10000	225	40	CK45
39D 866/5	8000	16000	273	50	CK45
39D 866/6	12500	25000	347	63	CK45
39D 866/7	31500	63000	422	76	42CrMo4 + QT
39D 866/25	8000	16000	221	50	CK45
39D 866/26	12500	25000	277	63	CK45

LIFTING PIN - TRAGBOLZEN MIT FALLRINGSICHERUNG - PERNO DI SOLLEVAMENTO

Only for replacement, until exhaustion of stocks
 Nur zur Reparatur, bis Bestand aufgebraucht ist
 Solo per riparazione, fino ad esaurimento scorte



Respect the max load
 Maximale Nutzlast beachten
 Rispettare il carico Max

WARNING - ACHTUNG - ATTENZIONE:

For safety reason, please consider always that the weight of the die has to be supported by just 2 lifting pins.

Aus Sicherheitsgründen stets berücksichtigen, dass zwei Tragbolzen das gesamte Werkzeuggewicht tragen müssen.

Per ragioni di sicurezza, considerare sempre che il peso dello stampo deve essere sopportato da 2 soli perni.



Standard VW/Audi

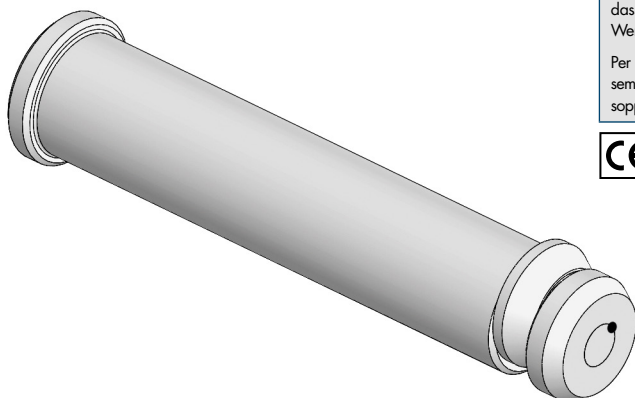

Security pin

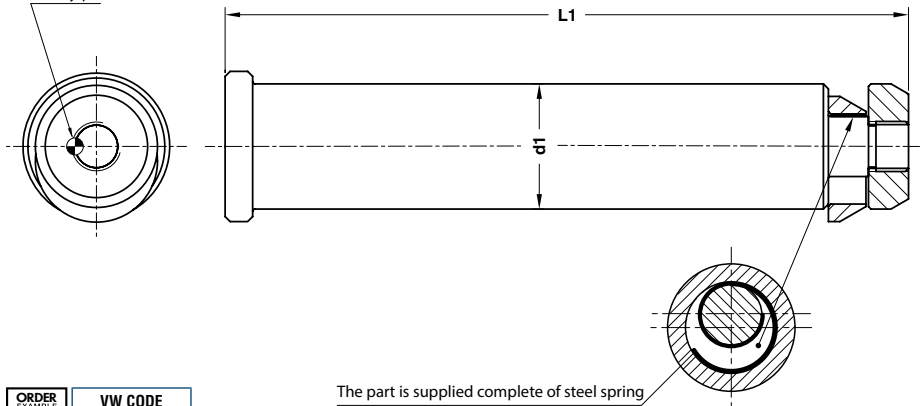

The part is supplied complete of steel spring

ORDER EXAMPLE	VW CODE
	39D 866/14

VW CODE	Max load (kg)	Max die weight (kg)	d1	L1	Material
39D 866/13	3200	6400	32	175	CK45
39D 866/14	5000	10000	40	225	CK45
39D 866/15	8000	16000	50	273	CK45
39D 866/16	12500	25000	63	347	CK45
39D 866/17	31500	63000	76	422	42CrMo4 + QT

BUSH FOR LIFTING PIN - BUCHSE FÜR TRAGBOLZEN - BOCCOLA PER PERNO DI SOLLEVAMENTO

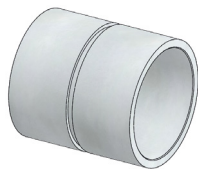

FORM A

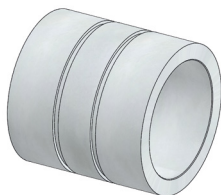
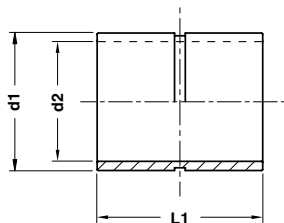

FORM B

Notes

Material: Si35

STOCK



VW CODE

39D 867/11

VW CODE	d1	d2	FORM
39D 867/10	44	34	A
39D 867/11	52	42	A
39D 867/12	62	52	A
39D 867/13	75	65	A
39D 867/14	100	78	B
39D 867/15	105	78	B

WASHER - SCHEIBE - RONDELLA

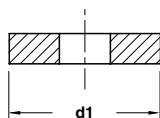
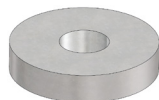

Notes

Material: CK45

STOCK



VW CODE
39D 869/10

VW CODE	d1
39D 869/3	35
39D 869/4	40
39D 869/5	50
39D 869/6	65
39D 869/8	80
39D 869/10	100
39D 869/13	130

Standard VW/Audi

39D 870

AIR CYLINDER FIXING - VERSCHRAUBUNG - FISSAGGIO CILINDRO

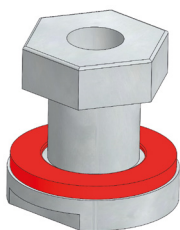

FORM A

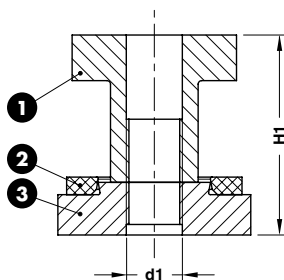

Notes

- 1 Material:** CK45
- 2 Material:** Elastomer 90 SH
- 3 Material:** CK45

STOCK



VW CODE
39D 870/20

VW CODE	d1	H1	FORM
39D 870/16	M16x1,5	57	A
39D 870/20	M20x1,5	63	A
39D 870/27	M27x2,0	65	B

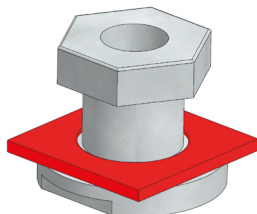

FORM B

CAM ROLLER - ROLLENBOCK - SUPPORTO CON RULLO

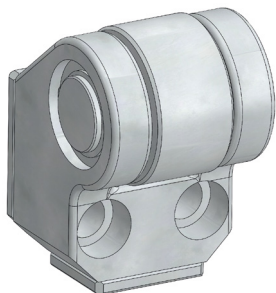

39D 872/20

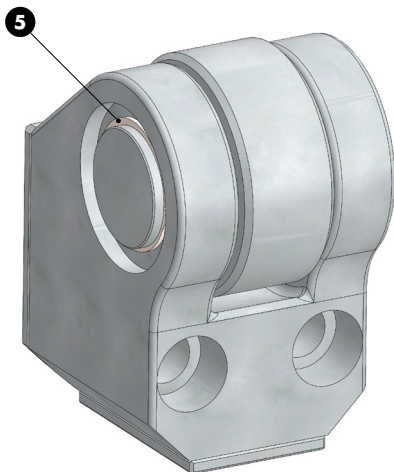

39D 872/21

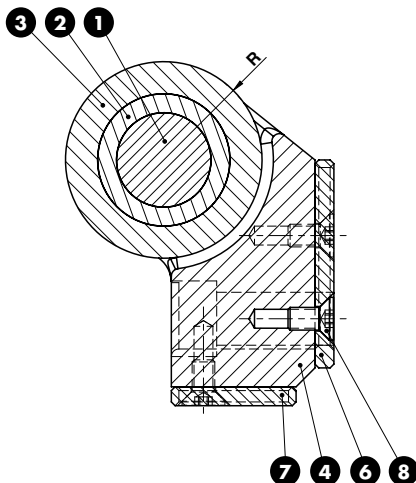

Notes	
1	Material: 16MnCr5 HRC: 60÷62
2	Material: Bronze + Graphite HB >190
3	Material: X210Cr12 HRC: 60÷62
4	Material: 42CrMo4
5	E25 DIN 471
6	7 Material: Si37
8	DIN EN ISO M6x12 (x5)



	VW CODE
	39D 872/21
VW CODE	
39D 872/20	
39D 872/21	

ACCELERATION CAM - SCHIEBERVORBESCHLEUNIGUNG - CAMMA DI ACCELERAZIONE

Notes

Materials: 90MnCrV8 - HRC: 60÷62

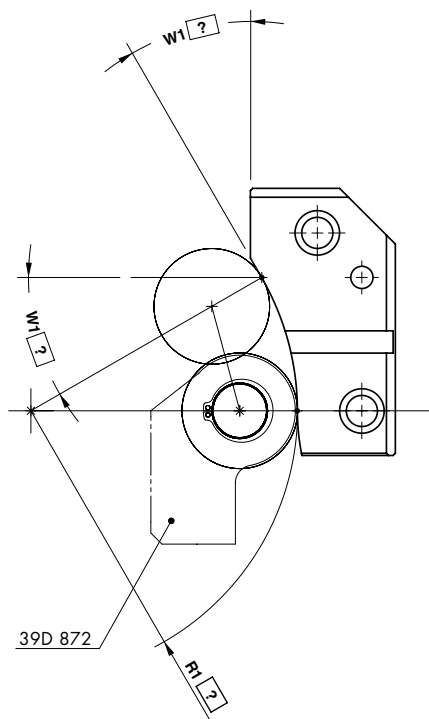
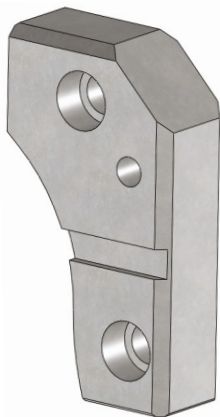

Standard VW/Audi

	VW CODE	W1?	R1?
	39D 873/10	W1=30°	R1=120

VW CODE	SIDE
39D 873/10	RIGHT
39D 873/11	LEFT

LIFTING BRACKET VDI 3366 - TRAGZAPFEN VDI 3366 - STAFFA DI SOLLEVAMENTO VDI 3366

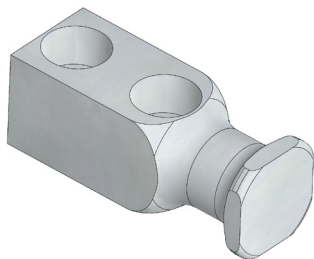

FORM A

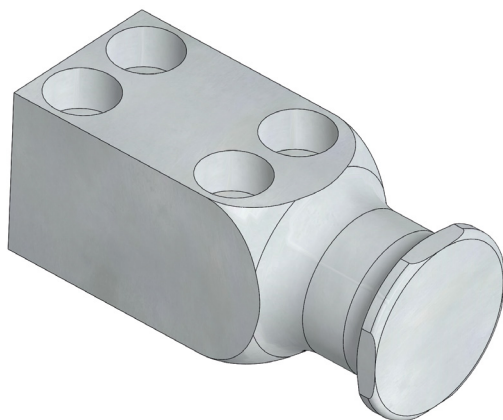

FORM B

Notes

Material: CK45 - 700÷800 N/mm²

Screws not included



STOCK



Respect the max load
Maximale Nutzlast beachten
Rispettare il carico Max

WARNING - ACHTUNG - ATTENZIONE:
For safety reason, please consider always that the weight of the die has to be supported by just 2 lifting brackets.

Aus Sicherheitsgründen stets berücksichtigen, dass zwei Tragzapfens das gesamte Werkzeuggewicht tragen müssen.

Per ragioni di sicurezza, considerare sempre che il peso dello stampo deve essere sopportato da 2 sole staffe.



VW CODE

39D 876/11

VW CODE	Max load (kg)	Max die weight (kg)	FORM	VW CODE	Max load (kg)	Max die weight (kg)	FORM
39D 876/10	320	640	A	39D 876/15	5000	10000	A
39D 876/11	630	1260	A	39D 876/16	8000	16000	B
39D 876/12	1250	2500	A	39D 876/17	12500	25000	B
39D 876/13	2000	4000	A	39D 876/18	20000	40000	B
39D 876/14	3200	6400	A				

AIR CYLINDER FIXING - ZIEHTEILHEBER - FISSAGGIO CILINDRO

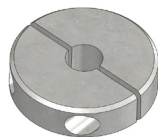

39D882/2

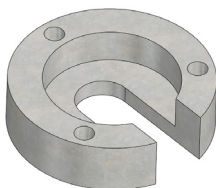

39D882/3

STOCK

Notes	
Material:	
39D882/2 - 34Cr4	
39D882/3 - CK45	

ORDER EXAMPLE	VW CODE
	39D 882/2

VW CODE	
39D 882/2	
39D 882/3	

AIR CYLINDER ADAPTER - TEILHEBER - ADATTATORE PER CILINDRO



Notes	
Material: CK45	

STOCK

ORDER EXAMPLE	VW CODE
	39D 887/1

VW CODE	
39D 887/1	

AIR CYLINDER ADAPTER - TEILHEBER - ADATTATORE PER CILINDRO

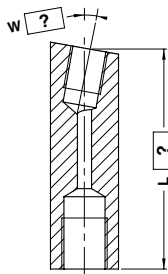
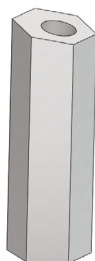

L max = 100	

Notes	
Material: CK45	

ORDER EXAMPLE	VW CODE	L=75	W=5°
	39D 887/2	75	5°

VW CODE	
39D 887/2	

Standard VW/Audi

**WEAR PLATE SELF-LUBRICATING
DECKLEISTE BRONZE MIT FESTSCHMIERSTOFF
PIASTRA GUIDA AUTOLUBRIFICANTE**

Notes

Material: Bronze + Graphite
HB > 190

STOCK

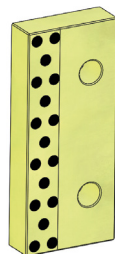

FORM A

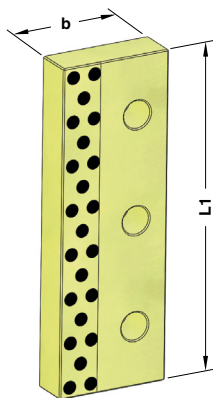

FORM B



FORM C

	VW CODE
	39D 890/26

VW CODE	b	L1	FORM	VW CODE	b	L1	FORM
39D 890/25	85	160	A	39D 890/16	125	200	A
39D 890/26	85	200	A	39D 890/17	125	250	B
39D 890/27	85	250	B	39D 890/18	125	300	B
39D 890/28	85	300	B	39D 890/19	125	350	B
39D 890/29	85	350	B	39D 890/20	125	400	C
39D 890/30	85	400	C	39D 890/21	125	450	C
39D 890/15	125	160	A	39D 890/22	125	500	C

WEAR PLATE DECKLEISTE SCHIEBERFÜHRUNG PIASTRA GUIDA

Notes

- 1 Material: CK45
- 2 39D 954/11÷39
- 3 DIN 912 M8x16

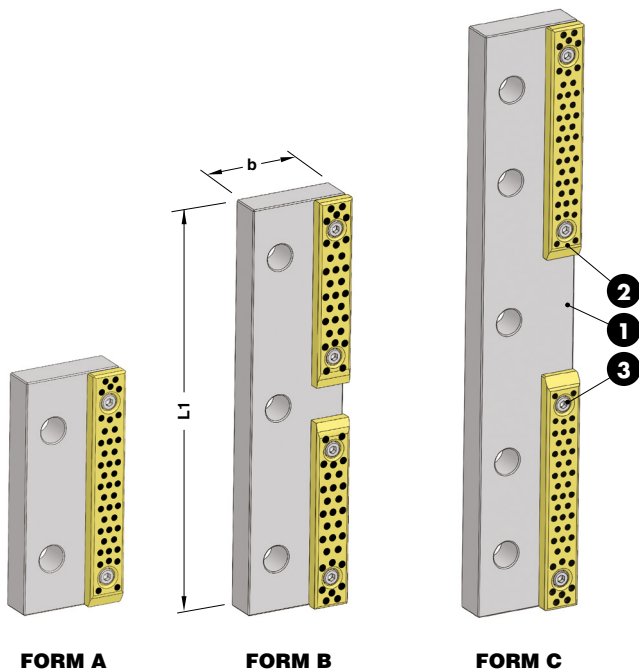

Standard VW/Audi

ORDER EXAMPLE	VW CODE
	39D 890/51

VW CODE	b	L1	FORM	VW CODE	b	L1	FORM
39D 890/50	85	160	A	39D 890/60	125	160	A
39D 890/51	85	200	A	39D 890/61	125	200	A
39D 890/52	85	250	B	39D 890/62	125	250	B
39D 890/53	85	300	B	39D 890/63	125	300	B
39D 890/54	85	350	B	39D 890/64	125	350	B
39D 890/55	85	400	C	39D 890/65	125	400	C
39D 890/56	85	450	C	39D 890/66	125	450	C
39D 890/57	85	500	C	39D 890/67	125	500	C

SINTERED STEEL WEAR PLATE GLEITPLATTE STAHL MIT SINTERGLEITFLÄCHE PIASTRA GUIDA IN ACCIAIO SINTERIZZATO

Notes

- 1 Material: CK45
- 2 39D 954/71÷99
- 3 DIN 912 M8x16

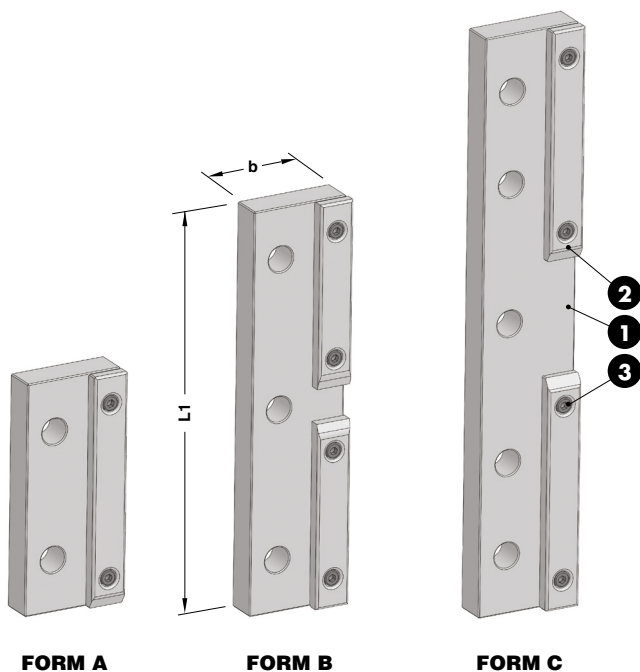

FORM A

FORM B

FORM C

ORDER EXAMPLE	VW CODE
	39D 890/71

VW CODE	b	L1	FORM	VW CODE	b	L1	FORM
39D 890/70	85	160	A	39D 890/80	125	160	A
39D 890/71	85	200	A	39D 890/81	125	200	A
39D 890/72	85	250	B	39D 890/82	125	250	B
39D 890/73	85	300	B	39D 890/83	125	300	B
39D 890/74	85	350	B	39D 890/84	125	350	B
39D 890/75	85	400	C	39D 890/85	125	400	C
39D 890/76	85	450	C	39D 890/86	125	450	C
39D 890/77	85	500	C	39D 890/87	125	500	C

GUIDE BAR SELF-LUBRICATING VDI 3357
FÜHRUNGSLEISTE BRONZE MIT FESTSCHMIERSTOFF VDI 3357
LARDONE AUTOLUBRIFICANTE VDI 3357

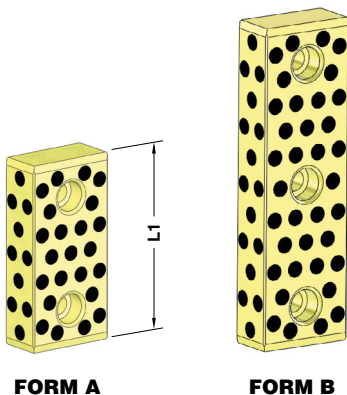

Notes
Material: Bronze + Graphite
HB > 190



	VW CODE
	39D 892/12

VW CODE	L1	FORM
39D 892/10	125	A
39D 892/11	160	A
39D 892/12	200	B
39D 892/15	125	A
39D 892/16	160	A
39D 892/17	200	B

Standard VW/Audi

CAM DWELL WEAR PLATE SELF-LUBRICATING VDI 3357
ÜBERLAUFKEILE BRONZE MIT FESTSCHMIERSTOFF VDI 3357
CUNEO AUTOLUBRIFICANTE VDI 3357

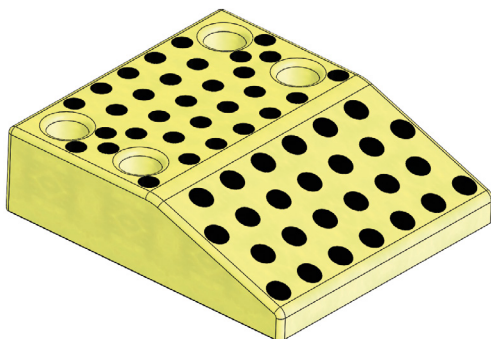

Notes

Material: Bronze + Graphite
HB > 190

STOCK

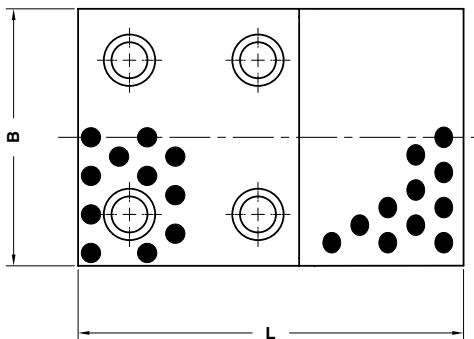
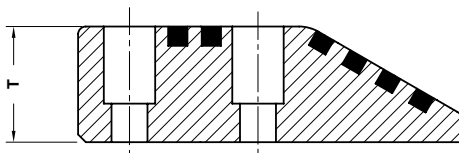

	VW CODE
	39D 894/131

VW CODE	B	L	T	VW CODE	B	L	T
39D 894/130	100	170	45	39D 894/136	125	150	45
39D 894/131	125	170	45	39D 894/137	125	170	60
39D 894/132	150	170	45	39D 894/138	150	150	45
39D 894/134	100	150	45	39D 894/139	150	170	60
39D 894/135	100	170	60				

CAM DWELL WEAR PLATE STEEL VDI 3357
ÜBERLAUFKEILE STAHL VDI 3357
CUNEO IN ACCIAIO VDI 3357

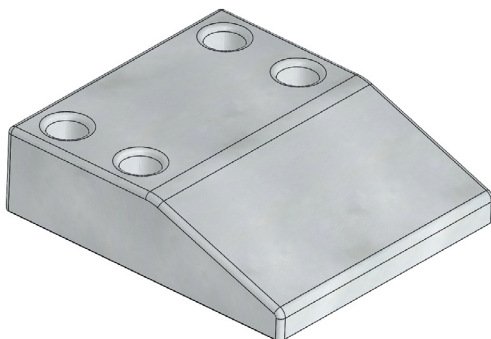

Notes
Material: X155CrVMo121KU
HRC: 58÷62

STOCK

Standard VW/Audi

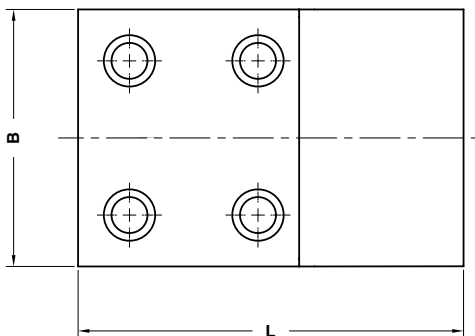
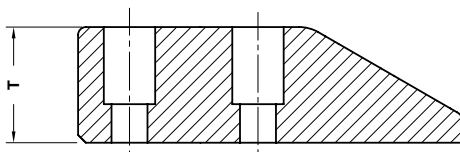

	VW CODE
	39D 894/151

VW CODE	B	L	T	VW CODE	B	L	T
39D 894/150	100	170	45	39D 894/156	125	150	45
39D 894/151	125	170	45	39D 894/157	125	170	60
39D 894/152	150	170	45	39D 894/158	150	150	45
39D 894/154	100	150	45	39D 894/159	150	170	60
39D 894/155	100	170	60				

BALANCE BLOCK - ENDDRUCKPLATTE - DISTANZIALE DI BATTUTA

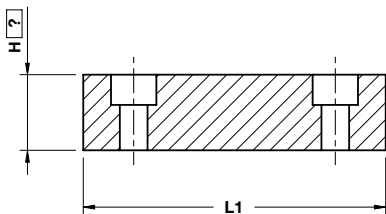
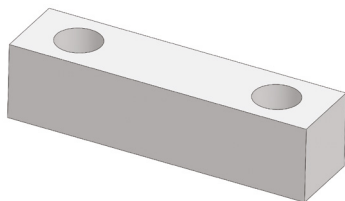

H min. = 30

Notes

Material: S137
 Only for replacement
 Nur für Reparatur
 Solo per riparazione



	VW CODE	H=35
	39D 895/11	35
VW CODE		L1
39D 895/1		80
39D 895/2		120
39D 895/3		200
39D 895/11		80
39D 895/12		120
39D 895/13		200

**COMPENSATION PIN GROUP
 AUSGLEICHSDRUCKBOLZEN
 GRUPPO PERNO DI COMPENSAZIONE**

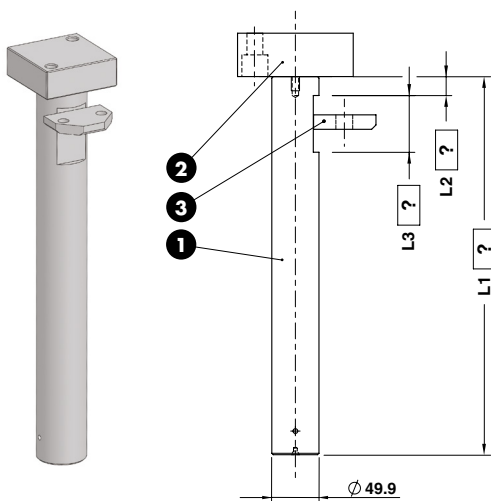

Notes

1 2 3

Material: 16MnCr5 - HRC: 60÷64



ORDER EXAMPLE	VW CODE	L1=400	L2=20	L3=60
	39D 896/1	400	20	60

VW CODE
39D 896/1

Standard VW/Audi

**COMPENSATION PIN GROUP
 AUSGLEICHSDRUCKBOLZEN
 GRUPPO PERNO DI COMPENSAZIONE**

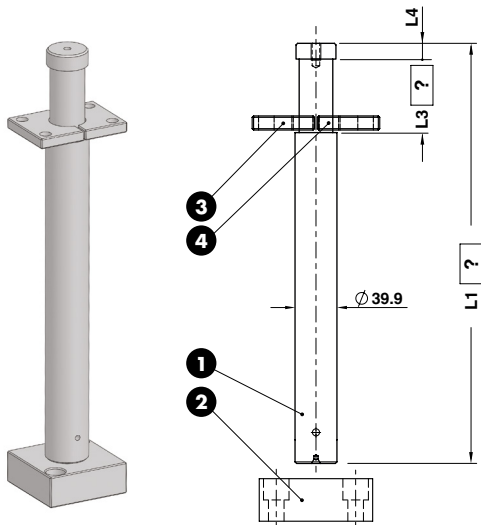

Notes

1 2 3 4

Material: 16MnCr5 - HRC: 60÷64



ORDER EXAMPLE	VW CODE	L1=300	L3=60	L4=45
	39D 896/2	300	60	45

VW CODE
39D 896/2

COMPENSATION PIN GROUP
AUSGLEICHSDRUCKBOLZEN
GRUPPO PERNO DI COMPENSAZIONE

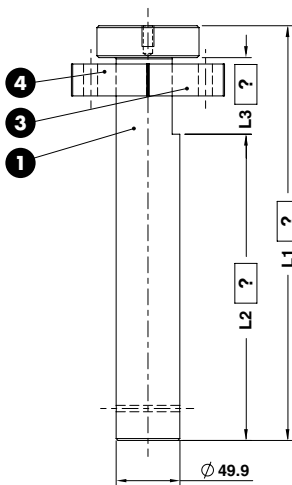

Notes

1 3 4

Material: 16MnCr5 - HRC: 60÷64



VW CODE	L1=325	L2=240	L3=60
39D 896/3	325	240	60

VW CODE

39D 896/3

COMPENSATION PIN GROUP
AUSGLEICHSDRUCKBOLZEN
GRUPPO PERNO DI COMPENSAZIONE

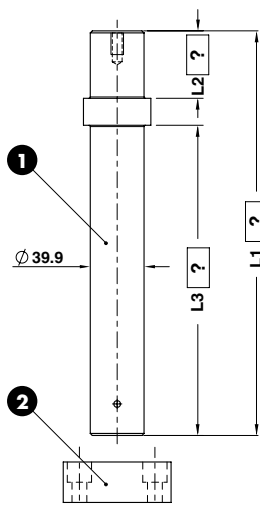

Notes

1 2

Material: 16MnCr5 - HRC: 60÷64



VW CODE	L1=300	L2=50	L3=230
39D 896/4	300	50	230

VW CODE

39D 896/4

BACKING PLATE - DISTANZKAPPE - REAZIONE PER CILINDRO



Notes

Material: 16MnCr5 - HRC: 60÷64

STOCK



VW CODE

39D 896/1-02

VW CODE

39D 896/1-02

RETAINER - SICHERUNGSPLATTE - PIASTRINA

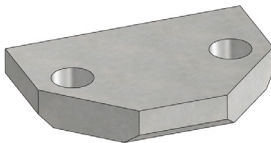

Notes

Material: 16MnCr5 - HRC: 60÷64

STOCK



VW CODE

39D 896/1-03

VW CODE

39D 896/1-03

RETAINER - SICHERUNGSPLATTE - PIASTRINA

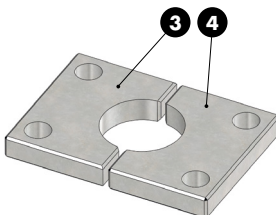

Notes

3 4

Material: 16MnCr5 - HRC: 60÷64

STOCK



VW CODE

39D 896/2-04

VW CODE

39D 896/2-03

39D 896/2-04

RETAINER - SICHERUNGSPLATTE - PIASTRINA

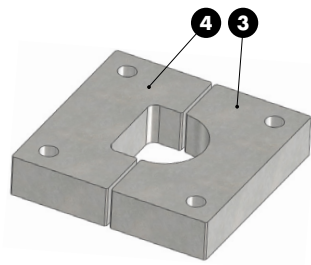

Notes

3 4

Material: 16MnCr5 - **HRC:** 60÷64

STOCK

ORDER
SAMPLE

VW CODE

39D 896/3-04

VW CODE

39D 896/3-03

39D 896/3-04

AIR PIN - UNTERLUFTBOLZEN - CANDELA



39D 951/1

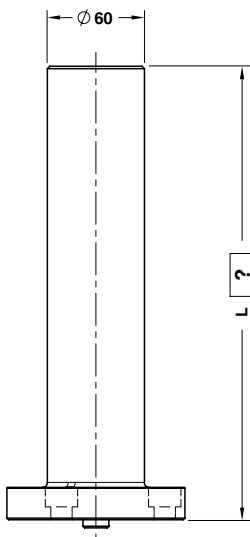

L max = 450

Notes
<p>Material: CK45 - 800÷1000 N/mm²</p> <p>Only for replacement Nur für Reparatur Solo per riparazione</p>



39D 951/2

ORDER EXAMPLE 	VW CODE	L=200
	39D 951/1	200

VW CODE
39D 951/1
39D 951/2

Standard VW/Audi

AIR PIN - UNTERLUFTBOLZEN - CANDELA



L max = 450

Notes

Material: CK45 - 800÷1000 N/mm²



39D 951/11



39D 951/12

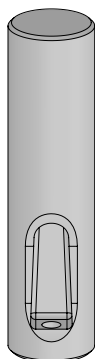
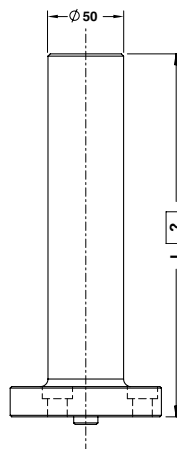

39D 951/22

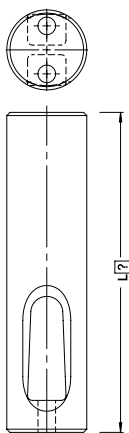

VW CODE	L=200
39D 951/12	200

VW CODE

39D 951/11
39D 951/12
39D 951/22

"V" DRIVER STEEL VDI 3357
PRISMENFÜHRUNG STAHL VDI 3357
GUIDA A "V" IN ACCIAIO VDI 3357

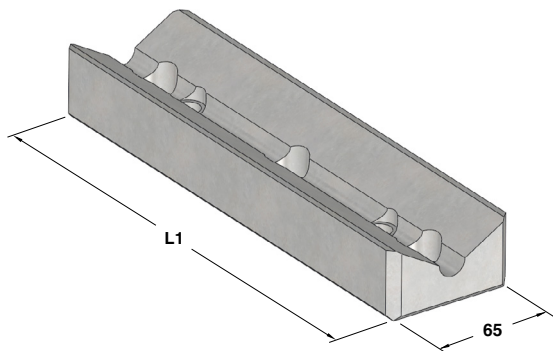

Notes

Material: CK45 - HRC: 58÷60

STOCK



VW CODE

39D 952/12

VW CODE	L1
39D 952/10	150
39D 952/11	200
39D 952/12	250
39D 952/13	300

"V" DRIVER STEEL VDI 3357
PRISMENFÜHRUNG STAHL VDI 3357
GUIDA A "V" IN ACCIAIO VDI 3357

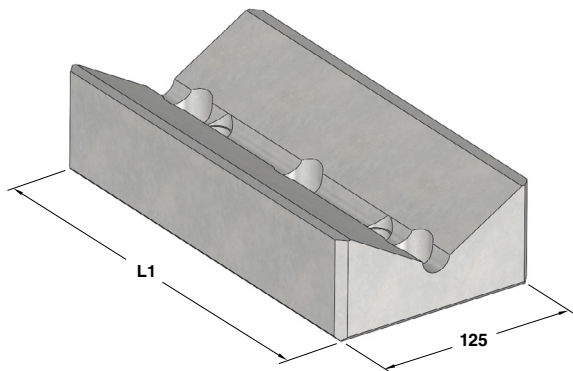

Notes

Material: CK45 - HRC: 58÷60

STOCK



VW CODE

39D 952/23

VW CODE	L1
39D 952/20	150
39D 952/21	200
39D 952/22	250
39D 952/23	300

"V" DRIVER SELF-LUBRICATING VDI 3357
PRISMENFÜHRUNG BRONZE MIT FESTSCHMIERSTOFF VDI 3357
GUIDA A "V" AUTOLUBRIFICANTE VDI 3357

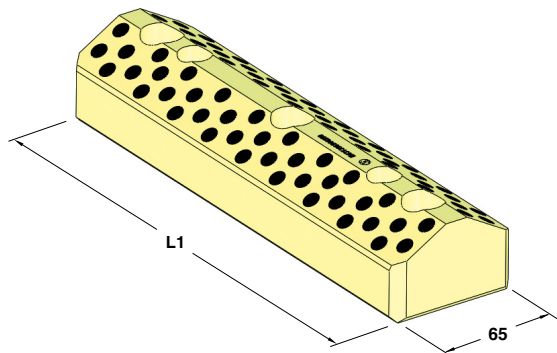

Notes

Material: Bronze + Graphite
HB >190

STOCK

ORDER
EXAMPLE

VW CODE
39D 952/43

VW CODE	L1
39D 952/40	150
39D 952/41	200
39D 952/42	250
39D 952/43	300

"V" DRIVER SELF-LUBRICATING VDI 3357
PRISMENFÜHRUNG BRONZE MIT FESTSCHMIERSTOFF VDI 3357
GUIDA A "V" AUTOLUBRIFICANTE VDI 3357

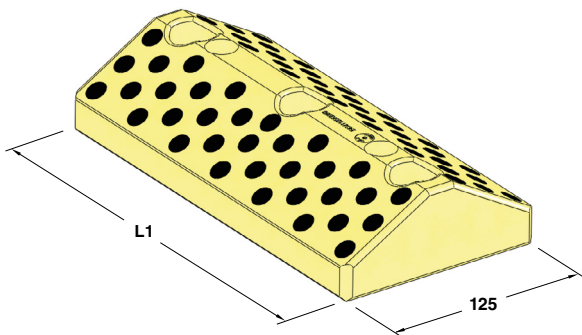

Notes

Material: Bronze + Graphite
HB >190

STOCK

ORDER
EXAMPLE

VW CODE
39D 952/52

VW CODE	L1
39D 952/50	150
39D 952/51	200
39D 952/52	250
39D 952/53	300

WEAR PLATE SELF-LUBRICATING VDI 3357
GLEITPLATTE BRONZE MIT FESTSCHMIERSTOFF VDI 3357
PIASTRA GUIDA AUTOLUBRIFICANTE VDI 3357

Notes

Material: Bronze + Graphite
HB > 190



FORM A

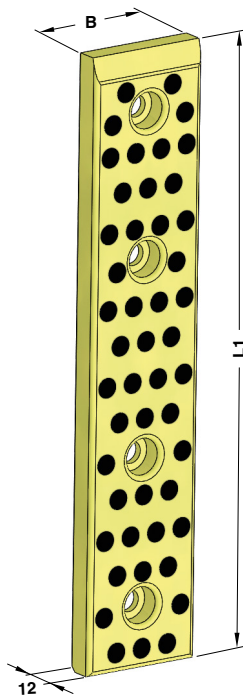

FORM B

	VW CODE
	39D 954/12

VW CODE	B	L1	FORM	VW CODE	B	L1	FORM	VW CODE	B	L1	FORM
39D 954/11	30	80	A	39D 954/21	50	80	A	39D 954/31	80	80	A
39D 954/12	30	100	A	39D 954/22	50	100	A	39D 954/32	80	100	A
39D 954/13	30	125	A	39D 954/23	50	125	A	39D 954/33	80	125	A
39D 954/14	30	160	A	39D 954/24	50	160	A	39D 954/34	80	160	A
39D 954/15	30	200	A	39D 954/25	50	200	A	39D 954/35	80	200	A
39D 954/16	40	80	A	39D 954/26	60	80	A	39D 954/36	50	250	B
39D 954/17	40	100	A	39D 954/27	60	100	A	39D 954/37	50	300	B
39D 954/18	40	125	A	39D 954/28	60	125	A	39D 954/38	50	350	B
39D 954/19	40	160	A	39D 954/29	60	160	A	39D 954/39	50	400	B
39D 954/20	40	200	A	39D 954/30	60	200	A				

Standard VW/Audi

WEAR PLATE STEEL VDI 3357
GLEITPLATTE STAHL VDI 3357
PIASTRA GUIDA IN ACCIAIO VDI 3357

Notes

Material: 16MnCr5 - **HRC:** 58÷60

STOCK

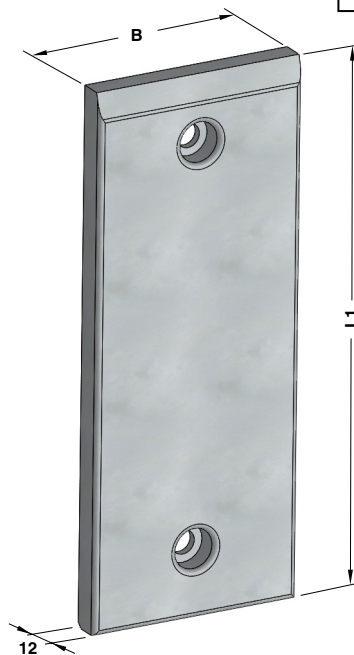

VW CODE

39D 954/42

VW CODE	B	L1	VW CODE	B	L1
39D 954/41	30	80	39D 954/54	50	160
39D 954/42	30	100	39D 954/55	50	200
39D 954/43	30	125	39D 954/56	60	80
39D 954/44	30	160	39D 954/57	60	100
39D 954/45	30	200	39D 954/58	60	125
39D 954/46	40	80	39D 954/59	60	160
39D 954/47	40	100	39D 954/60	60	200
39D 954/48	40	125	39D 954/61	80	80
39D 954/49	40	160	39D 954/62	80	100
39D 954/50	40	200	39D 954/63	80	125
39D 954/51	50	80	39D 954/64	80	160
39D 954/52	50	100	39D 954/65	80	200
39D 954/53	50	125			

SINTERED STEEL WEAR PLATE TYPE VDI 3357
GLEITPLATTE STAHL MIT SINTERGLEITFLÄCHE TIP VDI 3357
PIASTRA GUIDA IN ACCIAIO SINTERIZZATO TIPO VDI 3357

Notes

Material: Sintered metal

STOCK



FORM A

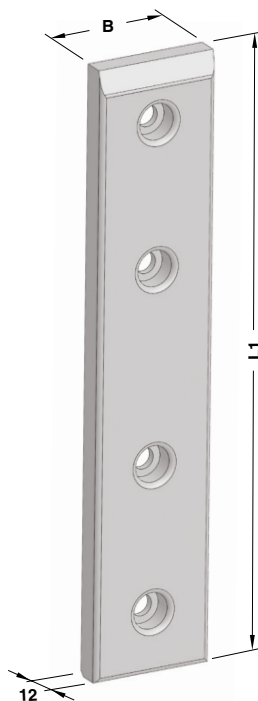

FORM B



VW CODE
39D 954/72

VW CODE	B	L1	FORM	VW CODE	B	L1	FORM	VW CODE	B	L1	FORM
39D 954/71	30	80	A	39D 954/81	50	80	A	39D 954/91	80	80	A
39D 954/72	30	100	A	39D 954/82	50	100	A	39D 954/92	80	100	A
39D 954/73	30	125	A	39D 954/83	50	125	A	39D 954/93	80	125	A
39D 954/74	30	160	A	39D 954/84	50	160	A	39D 954/94	80	160	A
39D 954/75	30	200	A	39D 954/85	50	200	A	39D 954/95	80	200	A
39D 954/76	40	80	A	39D 954/86	60	80	A	39D 954/96	50	250	B
39D 954/77	40	100	A	39D 954/87	60	100	A	39D 954/97	50	300	B
39D 954/78	40	125	A	39D 954/88	60	125	A	39D 954/98	50	350	B
39D 954/79	40	160	A	39D 954/89	60	160	A	39D 954/99	50	400	B
39D 954/80	40	200	A	39D 954/90	60	200	A				

GUIDE BUSH - FÜHRUNGSBUCHSE - BOCCOLA AUTOLUBRIFICANTE

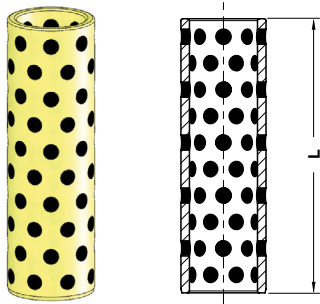

Notes

Material: Bronze + Graphite
HB >190

STOCK



VW CODE

39D 956/1

VW CODE

L

39D 956/1

115

39D 956/2

145

39D 956/3

170

39D 958

STOP PIN - HALTEBOLZEN - PERNO DI ARRESTO

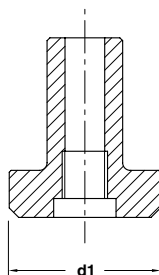

Notes

Material: 42CrMo4

Only for replacement
 Nur für Reparatur
 Solo per riparazione

STOCK



VW CODE

39D 958/2

VW CODE

d1

39D 958/1

100

39D 958/2

80

GUIDE POST DIN 9833 TYPE FÜHRUNGSSÄULE DIN 9833 TYP COLONNA GUIDA TIPO DIN 9833

Notes

Material: 1.6MnCr5

HRC: 60÷62

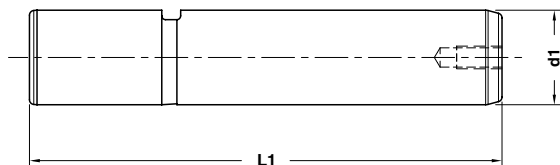

Standard VW/Audi

	VW CODE
	39D 969/47

VW CODE	d1	L1	VW CODE	d1	L1
39D 969/13	25	125	39D 969/45	50	250
39D 969/14	25	140	39D 969/46	50	280
39D 969/15	25	160	39D 969/47	50	315
39D 969/16	25	180	39D 969/48	50	355
39D 969/23	32	140	39D 969/53	63	224
39D 969/24	32	160	39D 969/54	63	250
39D 969/25	32	180	39D 969/55	63	280
39D 969/26	32	200	39D 969/56	63	315
39D 969/32	40	160	39D 969/57	63	355
39D 969/33	40	180	39D 969/58	63	400
39D 969/34	40	200	39D 969/64	80	250
39D 969/35	40	224	39D 969/65	80	280
39D 969/36	40	250	39D 969/66	80	315
39D 969/37	40	280	39D 969/67	80	355
39D 969/43	50	200	39D 969/68	80	400
39D 969/44	50	224			

LIFTER - FEDERBOLZEN - SOLLEVATORE

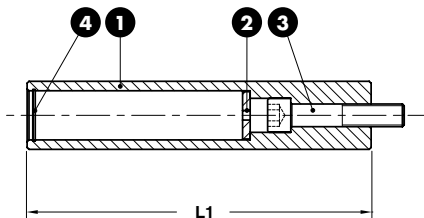
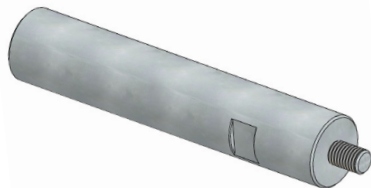

Notes

- 1 Material:** CK45 - **HRC:** 60÷62
- 2 Material:** 90MnCrV8
HRC: 54÷60
- 3** M10x60 DIN 912
- 4** Seeger ring DIN 472

STOCK



VW CODE

39D 972/11

VW CODE

L1

39D 972/11

182

39D 972/12

200

39D 972/13

220

SPACER PLATE TOOTHED - DISTANZPLATTE GEZAHNT - TASSELLO DI COMPENSAZIONE

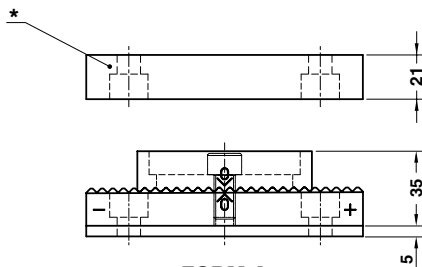
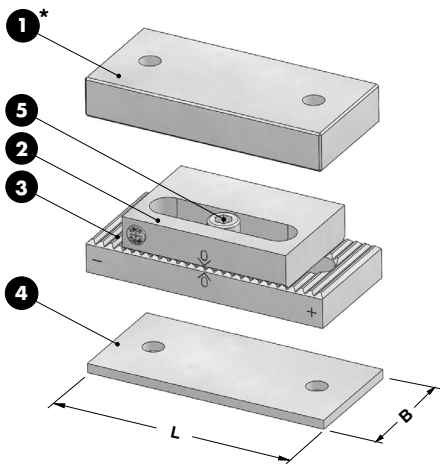

FORM A

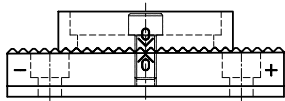

FORM B

Notes

1 2 3

Material: 90MnCrV8 - HRC: 58±60

4 Material: X155CrVMo12

5 DIN 912



* Pressure plate only in FORM A
Druckplatte nur bei Form A enthalten
Piastra di reazione solo in FORM A

Standard VW/Audi

ORDER EXAMPLE	VW CODE		
	39D 976/11		
VW CODE	L	B	FORM
39D 976/10	130	60	A
39D 976/11	160	80	A
39D 976/20	130	60	B
39D 976/21	160	80	B

PLATE FOR SENSOR - HALTERUNG - PIASTRINA PORTASENSORE

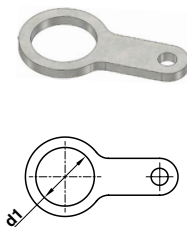

Notes

Material: Si37

STOCK



VW CODE
39D 993/1

VW CODE	d1
39D 993/1	19
39D 993/2	31

39D 995

SPACER - DISTANZSTÜCK - DISTANZIALE

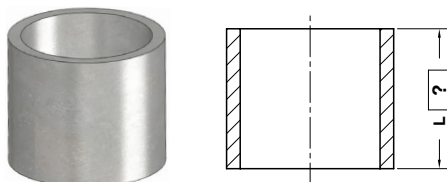

Notes

Material: CK45

10



VW CODE **L=37**
39D 995/4 37

VW CODE

39D 995/4

39D 995

SPACER - DISTANZSTÜCK - DISTANZIALE

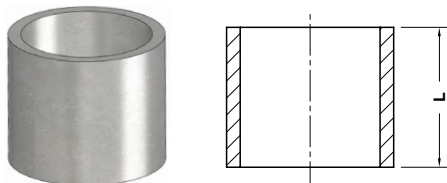

Notes

Material: CK45

STOCK



VW CODE
39D 995/4 L24

VW CODE	L	VW CODE	L	VW CODE	L	VW CODE	L	VW CODE	L
39D 995/4 L17	17	39D 995/4 L28	28	39D 995/4 L37	37	39D 995/4 L47	47	39D 995/4 L57	57
39D 995/4 L24	24	39D 995/4 L29	29	39D 995/4 L38	38	39D 995/4 L48	48	39D 995/4 L57,5	57,5
39D 995/4 L25	25	39D 995/4 L32	32	39D 995/4 L41	41	39D 995/4 L49	49	39D 995/4 L77	77
39D 995/4 L27	27	39D 995/4 L33	33	39D 995/4 L42	42	39D 995/4 L51	51		

WASHER/STOP BLOCK - SCHEIBE/HALTEPLATTE - RONDELLA/TASSELLO



39D 995/5



39D 995/6

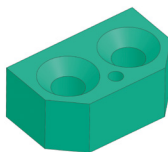

39D 995/8

Notes

Material:

39D 995/5 - CK45

39D 995/6 - 16MnCr5 - HRC: 60±62

39D 995/8 - Polyethylen PE-H

STOCK



VW CODE

39D 995/6

VW CODE

39D 995/5

39D 995/6

39D 995/8

Standard VW/Audi

RETAINER PIN - ZIEHTEILHEBER - PERNO CON RONDELLA

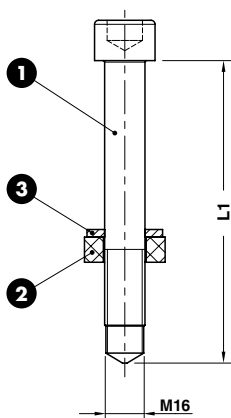

Notes

1 DIN 912

2 Material: Nylatron GSM P30

3 Material: STEEL

STOCK



VW CODE

39D 995/14

VW CODE

L1

39D 995/12

120

39D 995/14

135

39D 995/15

150

39D 995/16

160

DISTRIBUTOR - VERTEILERBLOCCKE - DISTRIBUTORE

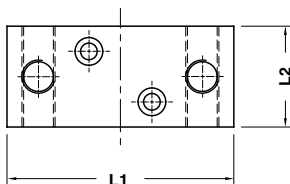
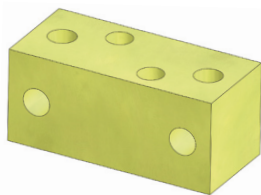

STOCK

Notes

Material: Ms65



VW CODE
39D 1392/1

VW CODE	L1	L2
39D 1392/1	90	40
39D 1392/2	100	45
39D 1392/3	110	50
39D 1392/4	120	60

DISTRIBUTOR - VERTEILERBLOCCKE - DISTRIBUTORE

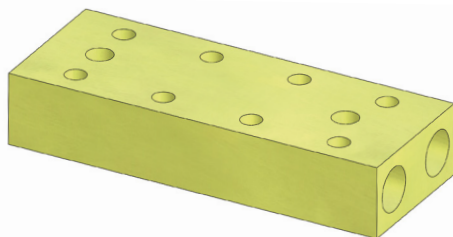

Notes

Material: Ms65

STOCK



VW CODE
39D 1430/1

VW CODE

39D 1430/1

DISTRIBUTOR - VERTEILERBLOCCKE - DISTRIBUTORE

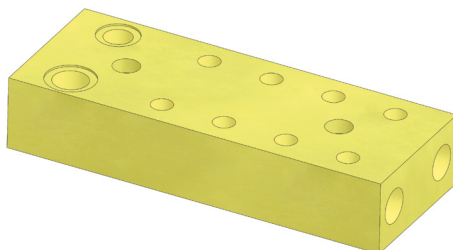

Notes

Material: Ms65

STOCK



VW CODE
39D 1497/2

VW CODE	CYLINDER DIAMETER
39D 1497/1	≤63
39D 1497/2	>63

**VISUAL LOCATOR SETTING PUNCH
STEMPEL F. ENTGASUNGSNOPPEN
PUNZONE DI VISUALIZZAZIONE**

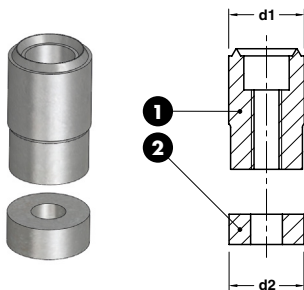

Notes

① **Material:** X205Cr12KU
HRC: 60÷62

② **Material:** X205Cr12KU

STOCK

	VW CODE
	39V 863/10

VW CODE	d1	d2
39V 863/10	10	9,7
39V 863/13	13	12

Standard VW/Audi

THREADED BUSH - GENWINDEBUCHSE - BOCCOLA FILETTATA

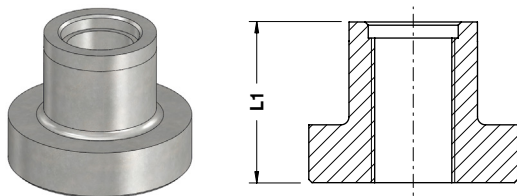

Notes

Material: CK45

STOCK

	VW CODE
	39V 1071

VW CODE	L1
39V 1071/1	50
39V 1071/2	87

GIB VDI 3387 - FÜHRUNGLASCHE VDI 3387 - GUIDA VDI 3387

Notes

Material: CK45 + Graphite
HRC: 58÷60

STOCK

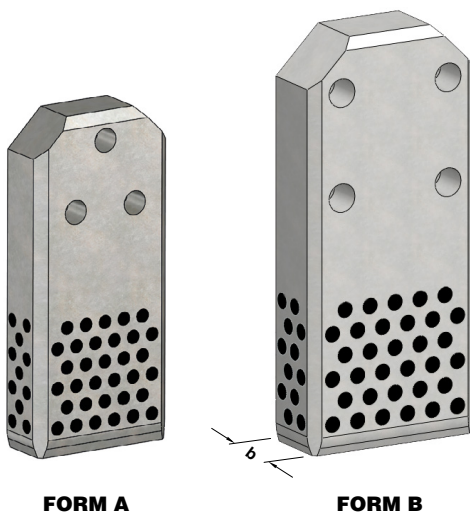

FORM A

FORM B

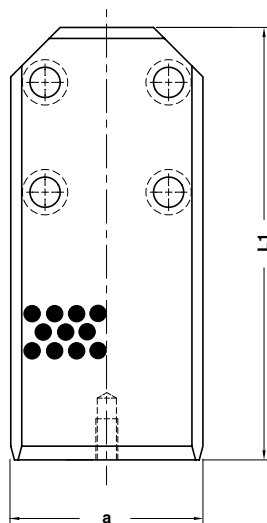

VW CODE
 39V 1159/25

VW CODE	a	b	L1	FORM
39V 1159/24	112	45	250	A
39V 1159/25	140	45	315	B
39V 1159/32	190	56	400	B
39V 1159/35	240	56	500	B
39V 1159/36	240	56	630	B
39V 1159/37	140	45	400	B
39V 1159/38	140	56	400	B

STOP BLOCK - ABSTANDSBLOCK - DISTANZIALE

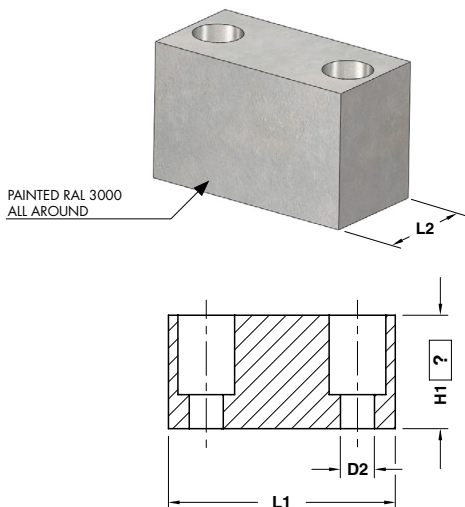

Notes

Material: CK45

Only for replacement
Nur für Reparatur
Solo per riparazione



	VW CODE	H1=60
	39V 1162/3	60

VW CODE	D2	L1	L2
39V 1162/1	9	60	40
39V 1162/2	11	80	40
39V 1162/3	14	100	40
39V 1162/4	14	100	50
39V 1162/5	14	120	60
39V 1162/6	14	150	80
39V 1162/7	14	160	100
39V 1162/20	18	150	80
39V 1162/21	18	160	100

Standard VW/Audi

STOP BLOCK - ABSTANDSBLOCK - DISTANZIALE

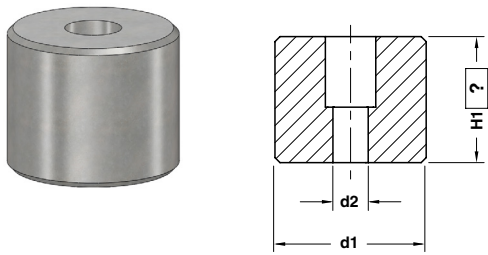

Notes

Material: CK45

Only for replacement
Nur für Reparatur
Solo per riparazione



	VW CODE	H1=60
	39V 1162/15	60

VW CODE	d1	d2
39V 1162/14	60	14
39V 1162/26	80	18
39V 1162/15	80	14
39V 1162/17	120	22
39V 1162/18	150	22
39V 1162/25	100	18

LOCATING CONE - KEGELDISTANZ - CONO DI CENTRAGGIO

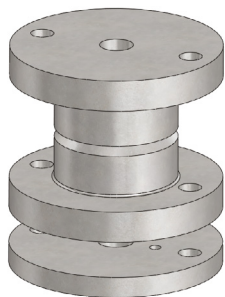

FORM A

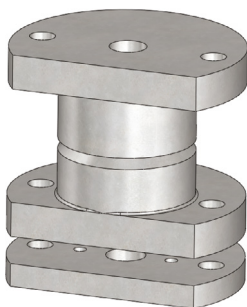

FORM B

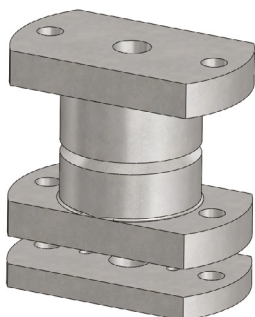

FORM C

Notes

1 2 **Material:** 16MnCr5
HRC: 58÷60

3 **Material:** CK45

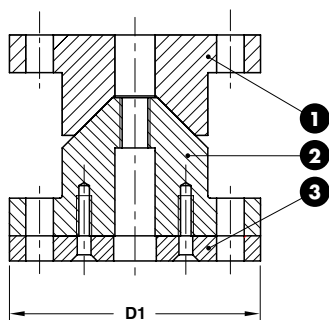

	VW CODE	
	39V 1168/16	
VW CODE	FORM	D1
39V 1168/10	A	100
39V 1168/12	A	120
39V 1168/14	B	100
39V 1168/16	B	120
39V 1168/18	C	100
39V 1168/20	C	120

COIL SPRING - SCHRAUBENFEDERN - MOLLA A FILO

Notes

Material: 50CrV4

STOCK

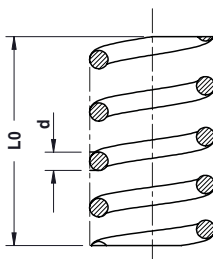

Standard VW/Audi



VW CODE
39V 1176/2

VW CODE	d	axb	L0	VW CODE	d	axb	L0
39V 1176/1	1,00	-	16,5	39V 1176/16	1,75	-	40,0
39V 1176/2	1,00	-	34,5	39V 1176/17	2,00	-	50,0
39V 1176/3	1,25	-	57,5	39V 1176/18	2,00	-	43,5
39V 1176/4	1,50	-	24,5	39V 1176/19	2,00	-	77,5
39V 1176/6	1,50	-	81,0	39V 1176/20	2,00	-	200,0
39V 1176/7	2,00	-	20,0	39V 1176/21	3,00	-	39,5
39V 1176/8	2,10	-	110,0	39V 1176/22	3,00	-	150,0
39V 1176/9	1,50	-	52,5	39V 1176/23	4,00	-	65,0
39V 1176/10	2,20	-	30,5	39V 1176/27	4,00	-	125,0

STRIPPER FOR BLANKING DIES - ABSTREIFER FÜR PLATINENSCHNITTE - ESTRATTORE PER STAMPI

Notes

Material: Elastomer 70 SH

STOCK

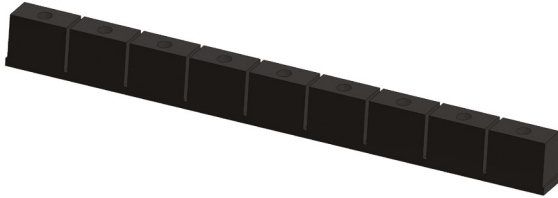

VW CODE

39V 1178/17

VW CODE

39V 1178/15

39V 1178/16

39V 1178/17

LIFTING PIN VDI 3366 - TRAGSCHRAUBE VDI 3366 - PERNO DI SOLLEVAMENTO VDI 3366

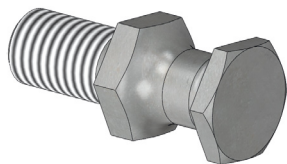

Respect the max load
Maximale Nutzlast beachten
Rispettare il carico Max

WARNING - ACHTUNG - ATTENZIONE:

For safety reason, please consider always that the weight of the die has to be supported by just 2 lifting pins.

Aus Sicherheitsgründen stets berücksichtigen, dass zwei Tragschrauben das gesamte Werkzeuggewicht tragen müssen.

Per ragioni di sicurezza, considerare sempre che il peso dello stampo deve essere sopportato da 2 soli perni.

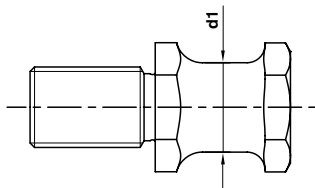

VW CODE
39V 1199/3

Notes

Material: CK45 - 700÷800 N/mm²

VW CODE	Max load (kg)	Max die weight (kg)	d1	VW CODE	Max load (kg)	Max die weight (kg)	d1
39V 1199/1	320	640	16	39V 1199/4	1500	3000	32
39V 1199/2	500	1000	20	39V 1199/5	2500	5000	40
39V 1199/3	1000	2000	25				

Standard VW/Audi

39V 1205

LOCATING PIN - ZENTRIERBOLZEN - CENTRAGGIO

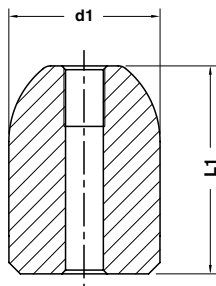

Notes
Material: 16MnCr5 - HRC: 58÷62



VW CODE
39V 1205/3

VW CODE	d1	L1
39V 1205/1	22	45
39V 1205/2	22	55
39V 1205/3	40	55
39V 1205/4	40	65
39V 1205/5	40	85

EJECTOR - ABDRÜCKSTIFT - ESPULSORE

Notes

Material: 16MnCr5
HRC: 58÷60

STOCK

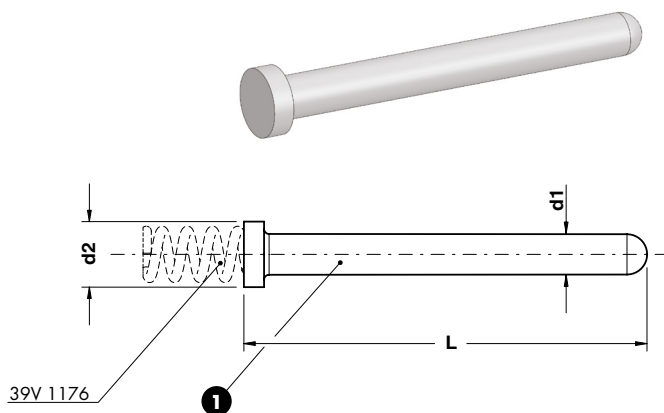

VW CODE

39V 1234/2

VW CODE	d1	d2	L	VW CODE	d1	d2	L	VW CODE	d1	d2	L
39V 1234/1	2,9	8	41	39V 1234/10	5,4	10	42	39V 1234/19	9,9	13	100
39V 1234/2	3,4	8	41	39V 1234/11	5,9	10	42	39V 1234/20	12,9	16	100
39V 1234/3	3,9	8	41	39V 1234/12	6,0	10	30	39V 1234/21	12,9	16	125
39V 1234/4	4,0	8	30	39V 1234/13	6,0	10	40	39V 1234/22	15,9	20	100
39V 1234/5	4,0	8	40	39V 1234/14	6,0	10	60	39V 1234/23	15,9	20	125
39V 1234/6	4,0	8	50	39V 1234/15	6,4	10	42	39V 1234/24	9,9	20	100
39V 1234/7	4,3	10	42	39V 1234/16	8,0	13	80	39V 1234/25	9,9	20	125
39V 1234/8	4,9	10	42	39V 1234/17	8,0	13	100	39V 1234/30	9,9	15	80
39V 1234/9	5,3	10	42	39V 1234/18	9,9	13	80				

GAGE - EINWEISER - RIFERIMENTO

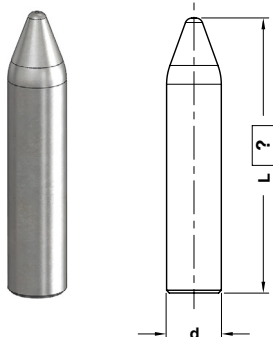

Notes

Material: 16MnCr5 - **HRC:** 58÷60

Only for replacement

Nur für Reparatur

Solo per riparazione



ORDER EXAMPLE 	VW CODE	L=100
	39V 1242/3	100

VW CODE	d
39V 1242/1	16
39V 1242/2	20
39V 1242/3	25

Standard VW/Audi

LOCATING BLOCK - FANGBACKE - TASSELLO DI CENTRAGGIO

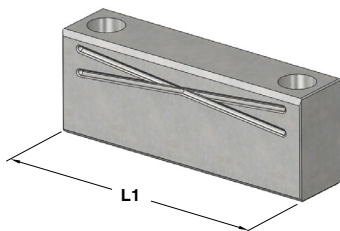

Notes

Material: 16MnCr5 - **HRC:** 60÷62



ORDER EXAMPLE 	VW CODE
	39V 1254/10

VW CODE	L1
39V 1254/10	100
39V 1254/11	125
39V 1254/12	160
39V 1254/13	200

KEY - PASSFEDER - CHIAVETTA

Notes

Material: CK45

STOCK

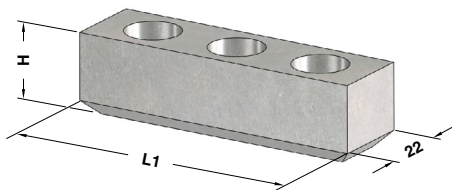

VW CODE

39V 1304/2

VW CODE	H	L1	VW CODE	H	L1	VW CODE	H	L1
39V 1304/1	14	50	39V 1304/7	22	50	39V 1304/11	40	50
39V 1304/2	14	80	39V 1304/8	22	80	39V 1304/12	40	80
39V 1304/3	14	100	39V 1304/9	22	100	39V 1304/13	40	100
39V 1304/4	14	125	39V 1304/10	22	125	39V 1304/14	40	125

39V 1304

KEY - PASSFEDER - CHIAVETTA

Notes

Material: CK45

STOCK

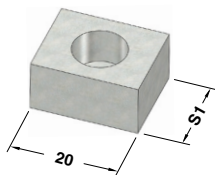

VW CODE

39V 1304/6

VW CODE	S1
39V 1304/5	12
39V 1304/6	16

ROLLER STOCK LIFTER - FEDERENDE LAUFROLLE - RULLINO SOLLEVAMENTO NASTRO

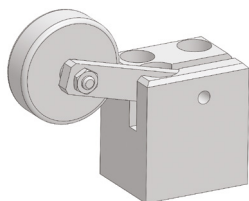

39V 1569/1

Notes	
1	Material: C15
2	Material: S235JRG2K
3	Material: 42CrMo4
5	Material: Steel
6	Spring
7	Screws M8x60 DIN 912

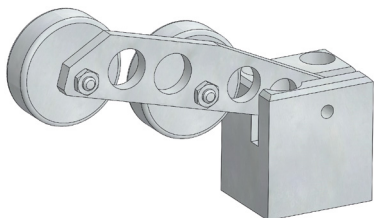
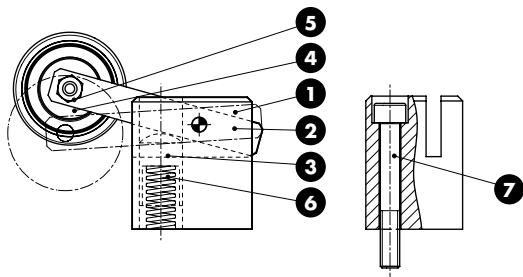

39V 1569/2

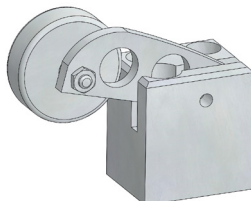

39V 1569/3

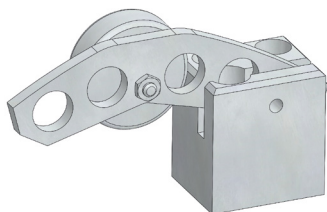

39V 1569/4

ORDER EXAMPLE	VW CODE
	39V 1569/2

VW CODE
39V 1569/1
39V 1569/2
39V 1569/3
39V 1569/4

Standard VW/Audi

ROLLER STOCK LIFTER - FEDERENDE LAUFROLLE - RULLINO SOLLEVAMENTO NASTRO

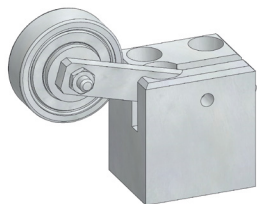

39V 1569/10

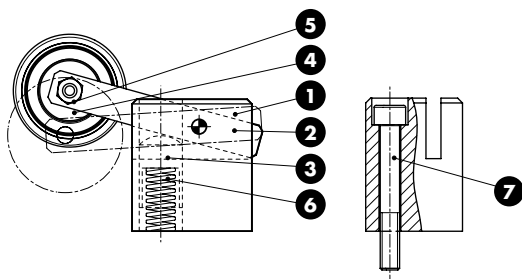

Notes	
1	Material: C15
2	Material: S235JRG2K
3	Material: 42CrMo4
4	Material: Steel
5	DIN 625-1 (6303-2Z)
6	Spring
7	Screws M8x60 DIN 912

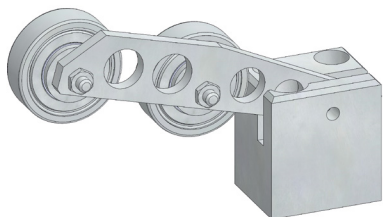

39V 1569/11

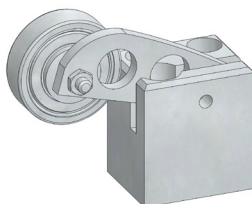

39V 1569/12
39V 1569/14

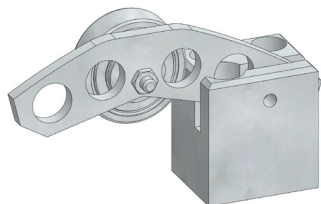

39V 1569/13

ORDER EXAMPLE	VW CODE
	39V 1569/11
VW CODE	
	39V 1569/10
	39V 1569/11
	39V 1569/12
	39V 1569/13
	39V 1569/14

ROLLER STOCK LIFTER - FEDERENDE LAUFROLLE - RULLINO SOLLEVAMENTO NASTRO

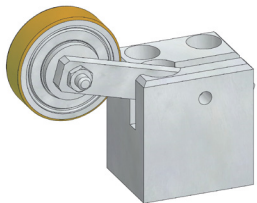

39V 1569/20

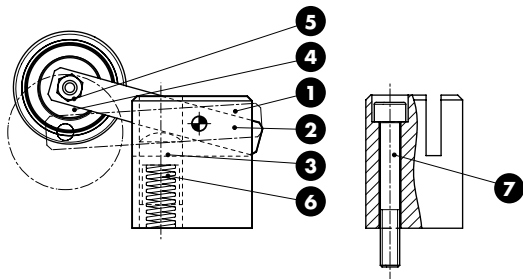

Notes	
1	Material: C15
2	Material: S235JRG2K
3	Material: 42CrMo4
4	Material: Steel
5	Material: Steel + Vulkolan
6	Spring
7	Screws M8x60 DIN 912



Standard VW/Audi

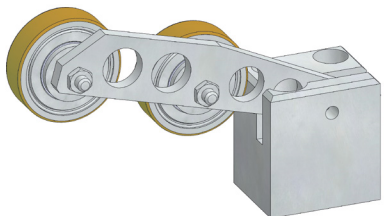

39V 1569/21

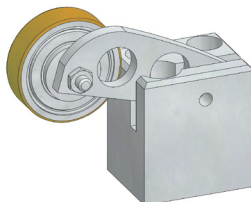

39V 1569/22

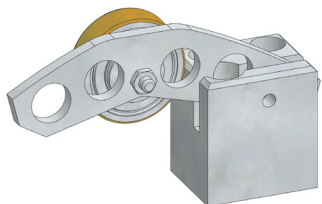

39V 1569/23

ORDER EXAMPLE	VW CODE
	39V 1569/21

VW CODE
39V 1569/20
39V 1569/21
39V 1569/22
39V 1569/23

GAGE WITH POSITION CONTROL KLAFFEINWEISER MIT LAGEKONTROLLE RIFERIMENTO CON CONTROLLO DI POSIZIONE

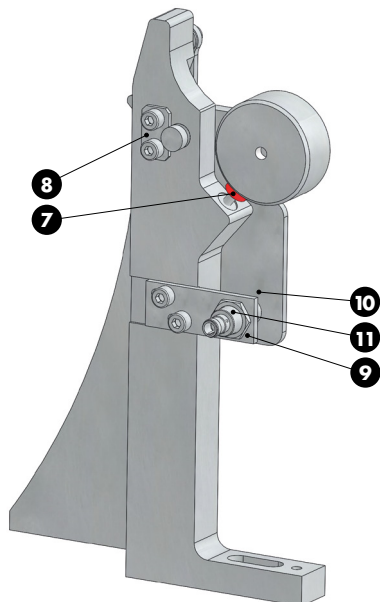

Notes

1 2 3 5 8

Material: 16MnCr5

4 9 10 Material: S235JRG2K

6 M10x30 DIN 7991

7 DESTACO 202208M

11 BALLUFF

12 C13.30.08012 (x2)

13 Washer PCM 241201.5M

14 E46.20.008012008

15 DIN 912 (x4)



* Bei Konstruktion festlegen
Set in construction
Realizzato in costruzione

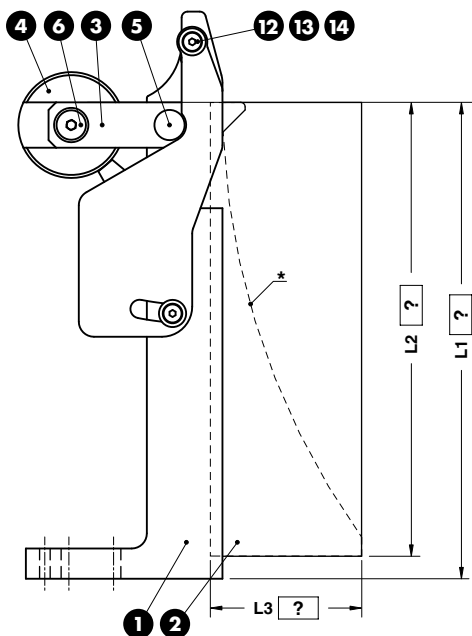

ORDER EXAMPLE	VW CODE	L1=315	L2=310	L3=50
	39D 22047/1	315	310	50

VW CODE

39D 22047/1

39D 22047/2



